

FY
FUNNY
FY

Un innovativo sistema d'arredo che crea uno spazio di lavoro collaborativo e che valorizza l'efficienza dei dipendenti. La protagonista, dal design sofisticato e moderno, è indubbiamente la scrivania, disponibile in sei strutture diverse e completamente personalizzabile combinando i numerosi materiali e i pregiati melaminici della gamma. L'ufficio raggiunge un equilibrio impeccabile e risulta piacevole e accogliente, sia per chi opera in postazione singola, che in team, alla reception o al call center.

Is eumqui ilitiam, qui ulpa quo voluptate que aut faceaque pa conem labo. Lorpos mint, illis que pos sanctum entoreped quia quae remquas reperro evellanist eum fugia natumquia doluptatur?

Is eumqui ilitiam, qui ulpa quo voluptate que aut faceaque pa conem labo. Lorpos mint, illis que pos sanctum entoreped quia quae remquas reperro evellanist eum fugia natumquia doluptatur?

Indice | Index | Index



Gamba Anello pag. 4
Ring Leg
Piètement en forme d'anneau



Gamba Csquare pag. 96
CsquareLeg
Piètement à Csquare



Gamba U pag. 32
U Leg
Piètement à U



Gamba Tsquare pag. 116
Tsquare Leg
Piètement à Tsquare



Fianco Legno pag. 66
Wood Side
Coté Boitè



Gamba T pag. 128
T Leg
Piètement à T



Smart Office pag. 142
Smart Office
Smart Office



Reception pag. 148
Reception
Reception



Archiviazione pag. 166
Storage
Rangement



Elettrificazione ed accessori pag. 182
Storage
Rangement

Gamba anello

Ring Leg

Anneau de jambe

Moderna e anticonvenzionale. La struttura con Gamba anello nasce per creare soluzioni d'arredo dalla forte personalità. Si raggiunge la massima libertà di composizione con i numerosi accostamenti disponibili tra i piani in melaminico o in vetro e le finiture della struttura in metallo.

Is eumqui ilitiam, qui ulpa quo voluptate que aut faceaque pa conem labo. Lorpos mint, illis que pos sanctum entoreped quia.

Is eumqui ilitiam, qui ulpa quo voluptate que aut faceaque pa conem labo. Lorpos mint, illis que pos sanctum entoreped quia.





Contrasto originale tra la struttura geometrica della gamba in metallo e il piano in melaminico. Una postazione di alta classe.

Is eumqui ilitiam, qui ulpa quo voluptate que aut faceaque pa conem labo. Lorpos mint, illis que pos sinctum.

Is eumqui ilitiam, qui ulpa quo voluptate que aut faceaque pa conem labo. Lorpos mint, illis que pos sinctum.



Il minimalismo del metallo trasmette tutta la professionalità sia per ambienti individuali, che per le zone comuni.

The elegance of the meeting area is conveyed by the harmonious combination of open elements and closed modules, shaped and modular tables, bases and consoles.

L'élégance de l'espace de réunion est transmise par le mariage d'éléments ouverts et de modules fermés, de tables profilées et modulaires, d'éléments bas et de consoles.





Nessun limite compositivo. La gamba anello si trasforma e diventa condivisa dando vita a un disegno dalla forte caratterizzazione e praticità.

Is eumqui ilitiam, qui ulpa quo voluptate que aut faceaque pa conem labo. Lorpos mint, illis que pos sinctum entoreped quia.

Is eumqui ilitiam, qui ulpa quo voluptate que aut faceaque pa conem labo. Lorpos mint, illis que pos sinctum entoreped quia.





Infinite soluzioni per l'archiviazione e il contenimento. La linea d'ufficio operativa si completa di cassettiere in metallo e mobili in melaminico con sofisticate finiture.

Is eumqui ilitiam, qui ulpa quo voluptate que aut faceaque pa conem labo. Lorpos mint, illis que pos sanctum entoreped quia.

Is eumqui ilitiam, qui ulpa quo voluptate que aut faceaque pa conem labo. Lorpos mint, illis que pos sanctum entoreped quia.







Le accoglienti postazioni di lavoro possono essere arricchite da schermi fonoassorbenti e dalla linearità eclettica della gamba anello condivisa.

Is eumqui ilitiam, qui ulpa quo voluptate que aut faceaque pa conem labo. Lorpos mint, illis que pos sinctum entoreped quia.

Is eumqui ilitiam, qui ulpa quo voluptate que aut faceaque pa conem labo. Lorpos mint, illis que pos sinctum entoreped quia.





**Il sistema d'appoggio che funge sia da archivio,
che da divisorio è la soluzione perfetta
per dotare la postazione di privacy
e massima funzionalità.**

*Is eumqui ilitiam, qui ulpa quo voluptate
que aut faceaque pa conem labo.
Lorpos mint, illis que pos sinctum
entoreped quia.*

*Is eumqui ilitiam, qui ulpa quo voluptate
que aut faceaque pa conem labo. Lorpos
mint, illis que pos sinctum entoreped quia.*







La struttura perimetrale della scrivania può essere affiancata da mobili di servizio freestanding su piedini di supporto, o su ruote per facilitarne la movimentazione.

Is eumqui ilitiam, qui ulpa quo voluptate que aut faceaque pa conem labo. Lorpos mint, illis que pos sinctum entoreped quia.

Is eumqui ilitiam, qui ulpa quo voluptate que aut faceaque pa conem labo. Lorpos mint, illis que pos sinctum entoreped quia.







Melaminico | Melamine | Mélangine

N3BD 25	Bianco Dance White Dance Blanc	N2GN 25	Grigio Nuvola Cloud Grey Nuage Gris	N2AN 25	Acero Nordic Nordic Maple Érable Nordic	N3RT 25	Rovere Twist Twist Durmast Twist Durmast
N2NO 25	Noce Walnut Noyer	N2GF 25	Grigio Fango Mud Grey Gris Mud	N3RV	Rovere Durmast Durmast	N3NA	Noce Napoli Walnut Napoli Noyer Napoli
N3NJ	Nero Jazz Jazz Black Noir Jazz						

Metallo | Metal | Métal

M2BD	Bianco Dance White Dance Blanc	M1NE	Nero Elegante Elegant Black Noir Éléphant	M2AG	Alluminio Goffrato Embossed Aluminum Aluminium Gaufré
------	--------------------------------------	------	---	------	---

Vetro | Glass | Verre

E1BD	Bianco Dance White Dance Blanc	E1GY	Grigio Yoga Yoga Grey Gris Yoga	V1NE	Nero Elegante Elegant Black Noir Éléphant	E1TT	Titanio Titanium Titane
E1GF	Grigio Fango Mud Grey Gris Mud	V1BV	Blu Vivo Living Blue Bleu Vif	E1MS	Marsala Marsala Marsala	V1MK	Moka Moka Moka
E1DE	Denim Denim Denim	E1VF	Verde Foresta Green Forest Forêt verte				

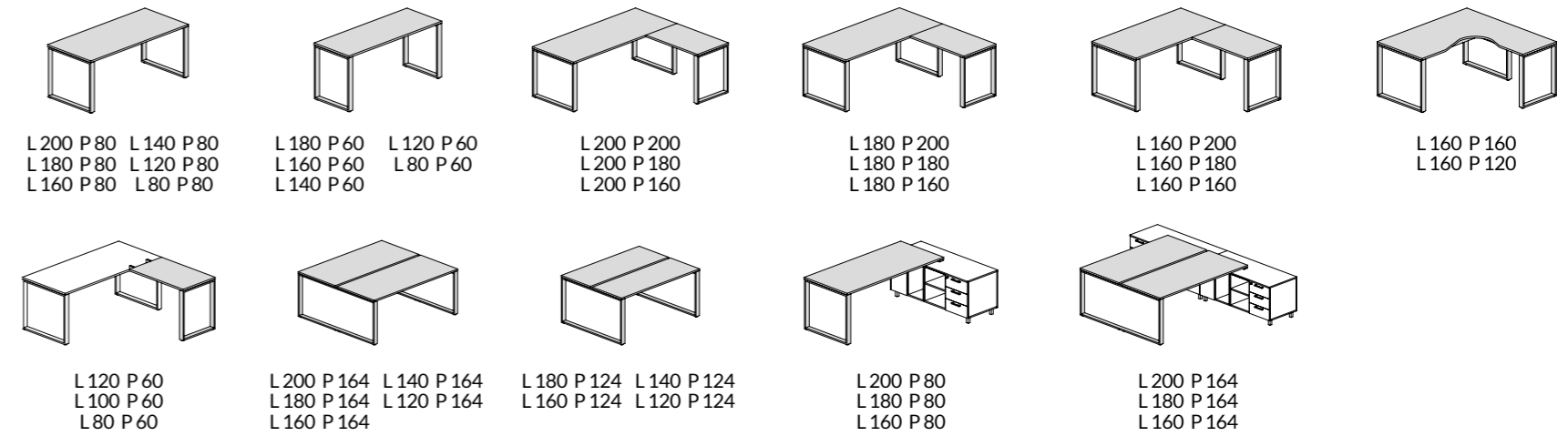

Tavoli riunione in melaminico | Desks | Bureaux

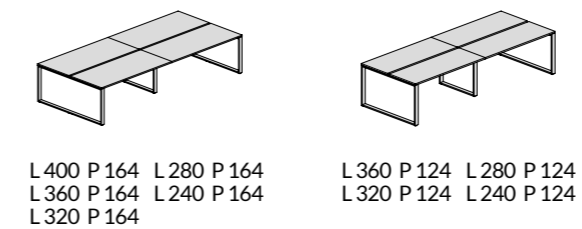

Scrivanie e bench in vetro | Desks | Bureaux

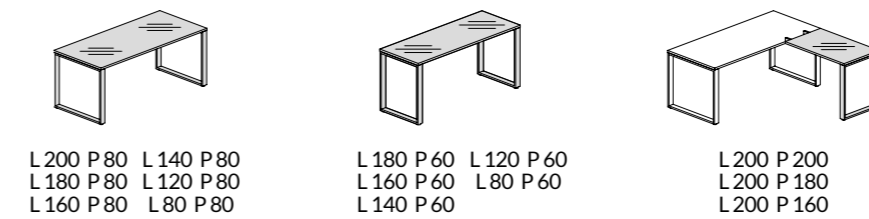

Composizioni con mobili filo-piano | Desks | Bureaux

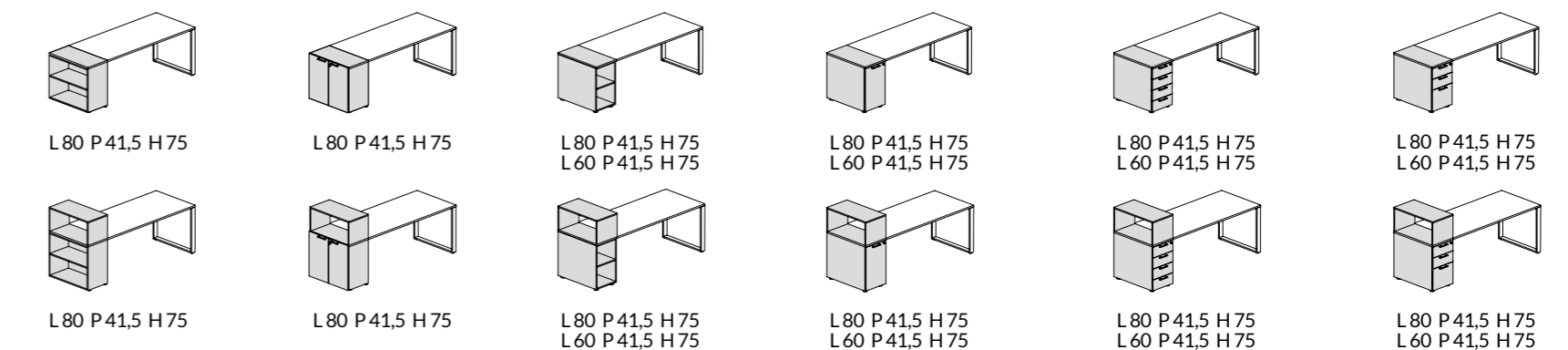

Tutti i componenti si integrano tra loro con armonia combinando le finiture in melaminico e le superfici in vetro con il metallo della struttura.

Is eumqui ilitiam, qui ulpa quo voluptate que aut faceaque pa conem labo. Lorpos mint, illis que pos sinctum.

Is eumqui ilitiam, qui ulpa quo voluptate que aut faceaque pa conem labo. Lorpos mint, illis que pos sinctum.

Gamba U

U Leg

Jambe U

Minimal, ma significativa.

Dalla struttura metallica pura ed essenziale della gamba U si genera una postazione lavorativa d'impatto. Libertà di espressione con diverse combinazioni cromatiche e materiche delle superfici. L'ufficio prende vita e risponde a tutti gli impieghi richiesti.

Is eumqui ilitiam, qui ulpa quo voluptate que aut faceaque pa conem labo. Lorpos mint, illis que pos sinctum entoreped quia.

Is eumqui ilitiam, qui ulpa quo voluptate que aut faceaque pa conem labo. Lorpos mint, illis que pos sinctum entoreped quia.





La possibilità di scelta tra piano di lavoro in melaminico o vetro caratterizza l'ambiente ufficio con due stili completamente diversi.

Is eumqui ilitiam, qui ulpa quo voluptate que aut faceaque pa conem labo. Lorpos mint, illis que pos sintum.

Is eumqui ilitiam, qui ulpa quo voluptate que aut faceaque pa conem labo. Lorpos mint, illis que pos sintum.







Il tavolo quadrato riformula la tradizionale sala riunione; dimensioni ottimali per ricavare un'area meeting nello spazio condiviso con le postazioni operative.

Is eumqui ilitiam, qui ulpa quo voluptate que aut faceaque pa conem labo. Lorpos mint, illis que pos sinctum entoreped quia.

Is eumqui ilitiam, qui ulpa quo voluptate que aut faceaque pa conem labo. Lorpos mint, illis que pos sinctum entoreped quia.







Scegliere un mobile di servizio di supporto al piano di lavoro è il giusto compromesso tra funzionalità e uno spazio ridotto; la componibilità dei moduli consente di individuare la soluzione più adatta alle proprie esigenze.

Is eumqui ilitiam, qui ulpa quo voluptate que aut faceaque pa conem labo. Lorpos mint, illis que pos sinctum entoreped quia.Lo corata cuptur sero occum cumqui vit, il idus porersperios excesto et.

Is eumqui ilitiam, qui ulpa quo voluptate que aut faceaque pa conem labo. Lorpos mint, illis que pos sinctum entoreped quia.Lo corata cuptur sero occum cumqui vit, il idus porersperios excesto et.



Le postazioni bench permettono di ospitare capienti mobili di servizio, freestanding o portanti, posizionandoli sotto il piano di lavoro.

The elegance of the meeting area is conveyed by the harmonious combination of open elements and closed modules, shaped and modular tables, bases and consoles.

L'élégance de l'espace de réunion est transmise par le mariage d'éléments ouverts et de modules fermés, de tables profilées et modulaires, d'éléments bas et de consoles.





Totale condivisione degli spazi e massima libertà di movimento grazie alla componibilità delle postazioni di lavoro frontali con gamba U condivisa e gamba anello centrale.

Is eumqui ilitiam, qui ulpa quo voluptate que aut faceaque pa conem labo. Lorpos mint, illis que pos sinctum entoreped quia.

Is eumqui ilitiam, qui ulpa quo voluptate que aut faceaque pa conem labo. Lorpos mint, illis que pos sinctum entoreped quia.



Gli schermi divisorii in melaminico risultano indispensabili per conferire il giusto livello di privacy a postazioni di lavoro contrapposte.

Is eumqui ilitiam, qui ulpa quo voluptate que aut faceaque pa conem labo. Lorpos mint, illis que pos sinctum entoreped quia.

Is eumqui ilitiam, qui ulpa quo voluptate que aut faceaque pa conem labo. Lorpos mint, illis que pos sinctum entoreped quia.





Le diverse combinazioni cromatiche delle finiture catturano lo sguardo e vivacizzano i contenitori modulari Lockers in modo accattivante.

Is eumqui ilitiam, qui ulpa quo voluptate que aut faceaque pa conem labo. Lorpos mint, illis que pos sanctum entoreped quia.

Is eumqui ilitiam, qui ulpa quo voluptate que aut faceaque pa conem labo. Lorpos mint, illis que pos sanctum entoreped quia.



I mobili filo piano si integrano alla scrivania fungendo sia da pratici contenitori che da moduli a giorno ideali per suddividere le postazioni; connubio ottimale di archiviazione e privacy.

Is eumqui ilitiam, qui ulpa quo voluptate que aut faceaque pa conem labo. Lorpos mint, illis que pos sinctum entoreped quia.

Is eumqui ilitiam, qui ulpa quo voluptate que aut faceaque pa conem labo. Lorpos mint, illis que pos sinctum entoreped quia.





Ambienti ufficio completi e funzionali grazie alla possibilità di combinare scrivanie, contenitori e tavoli riunione con finiture e materiali diversi ma del tutto abbinabili.

The elegance of the meeting area is conveyed by the harmonious combination of open elements and closed modules, shaped and modular tables, bases and consoles.

L'élégance de l'espace de réunion est transmise par le mariage d'éléments ouverts et de modules fermés, de tables profilées et modulaires, d'éléments bas et de consoles.

La gamba U propone numerose soluzioni per lo spazio riunione, tutte caratterizzate da linee rigorose e pulite in grado di valorizzare l'ambiente.

The elegance of the meeting area is conveyed by the harmonious combination of open elements and closed modules, shaped and modular tables, bases and consoles.

L'élégance de l'espace de réunion est transmise par le mariage d'éléments ouverts et de modules fermés, de tables profilées et modulaires, d'éléments bas et de consoles.





L'estensione longitudinale di bench e scrivanie in appoggio su mobili di servizio dà forma a composizioni dinamiche, creando ambienti di lavoro funzionali e confortevoli.

Is eumqui ilitiam, qui ulpa quo voluptate que aut faceaque pa conem labo. Lorpos mint, illis que pos sinctum entoreped quia.

Is eumqui ilitiam, qui ulpa quo voluptate que aut faceaque pa conem labo. Lorpos mint, illis que pos sinctum entoreped quia.









Melaminico | Melamine | Mélamine

N3BD 25	Bianco Dance White Dance Blanc	N2GN 25	Grigio Nuvola Cloud Grey Nuage Gris	N2AN 25	Acero Nordic Nordic Maple Érable Nordici	N3RT 25	Rovere Twist Twist Durmast Twist Durmast
N2NO 25	Noce Walnut Noyer	N2GF 25	Grigio Fango Mud Grey Gris Mud	N3RV	Rovere Durmast Durmast	N3NA	Noce Napoli Walnut Napoli Noyer Napoli
N3NJ	Nero Jazz Jazz Black Noir Jazz						

Metallo | Metal | Métal

M2BD	Bianco Dance White Dance Blanc	M1NE	Nero Elegante Elegant Black Noir Éléphant	M2AG	Alluminio Goffrato Embossed Aluminum Aluminium Gaufré
------	---	------	--	------	--

Vetro | Glass | Verre

E1BD	Bianco Dance White Dance Blanc	E1GY	Grigio Yoga Yoga Grey Gris Yoga	V1NE	Nero Elegante Elegant Black Noir Éléphant	E1TT	Titanio Titanium Titane
E1GF	Grigio Fango Mud Grey Gris Mud	V1BV	Blu Vivo Living Blue Bleu Vif	E1MS	Marsala Marsala Marsala	V1MK	Moka Moka Moka
E1DE	Denim Denim Denim	E1VF	Verde Foresta Green Forest Forêt verte				

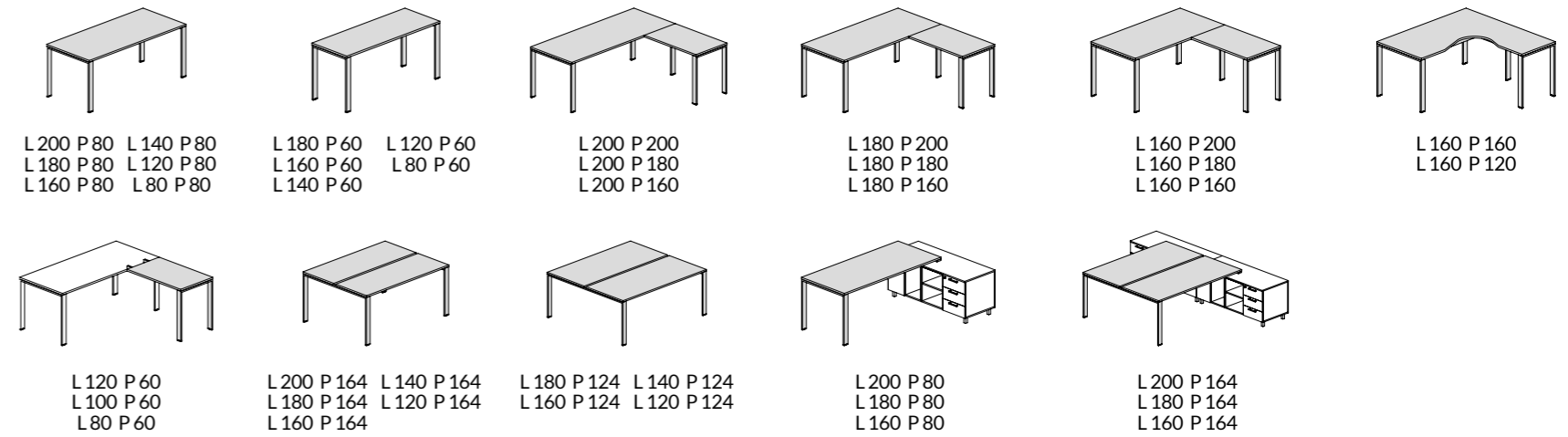

Tavoli riunione in melaminico | Desks | Bureaux

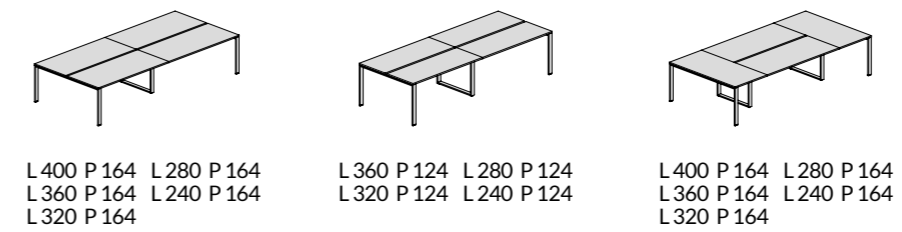

Scrivanie e bench in vetro | Desks | Bureaux

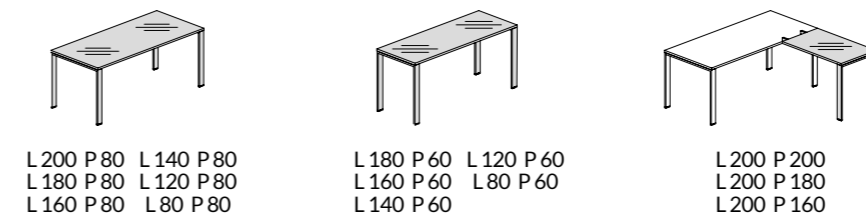

Tavoli riunione in vetro | Desks | Bureaux

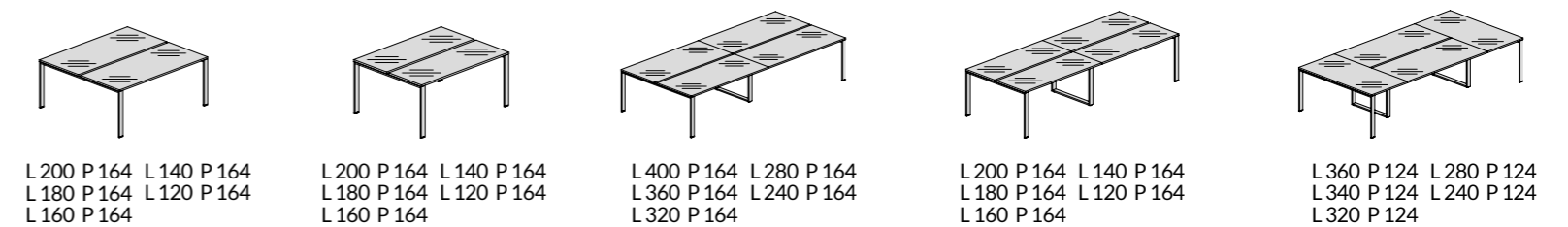

Composizioni con mobili filo-piano | Desks | Bureaux

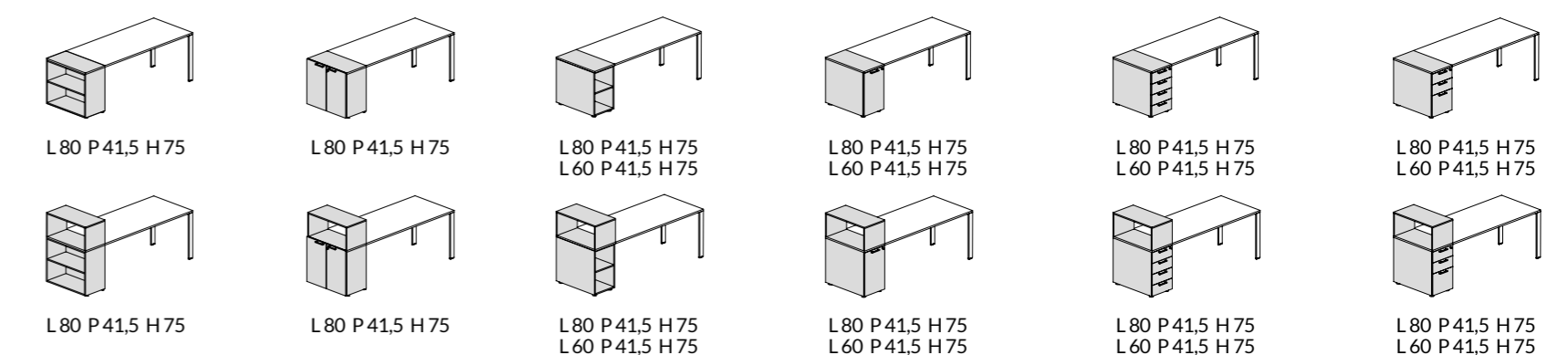

L'estetica dell'ambiente lavorativo soddisferà ogni tipo di gusto con i diversi accostamenti realizzabili tra le finiture cromatiche e i materiali ricercati.

Is eumqui ilitiam, qui ulpa quo voluptate que aut faceaque pa conem labo. Lorpos mint, illis que pos sinctum entoreped quia.

Is eumqui ilitiam, qui ulpa quo voluptate que aut faceaque pa conem labo. Lorpos mint, illis que pos sinctum entoreped quia.

Fianco Legno

Wood Side

Cotè Boitè

La superficie classica e rigorosa del fianco legno è il segreto per un'estetica sempre attuale ed estremamente elegante. Il design pratico ed ergonomico soddisfa tutte le esigenze dell'ufficio operativo e dà vita a una scrivania lineare dalla capacità compositiva infinita.

Is eumqui ilitiam, qui ulpa quo voluptate que aut faceaque pa conem labo. Lorpos mint, illis que pos sinctum entoreped quia.

Is eumqui ilitiam, qui ulpa quo voluptate que aut faceaque pa conem labo. Lorpos mint, illis que pos sinctum entoreped quia.





Comodità e contemporaneità si coniugano con i volumi e con le superfici composte, affiancando alla scrivania un mobile di servizio indipendente.

Is eumqui ilitiam, qui ulpa quo voluptate que aut faceaque pa conem labo. Lorpos mint, illis que pos sinctum entoreped quia.

Is eumqui ilitiam, qui ulpa quo voluptate que aut faceaque pa conem labo. Lorpos mint, illis que pos sinctum entoreped quia.





L'innovativa finitura Rovere realizzata con un melaminico di ultima generazione si sposa alla perfezione con le superfici bianche dei mobili d'archivio.

Is eumqui ilitiam, qui ulpa quo voluptate que aut faceaque pa conem labo. Lorpos mint, illis que pos sanctum entoreped quia.

Is eumqui ilitiam, qui ulpa quo voluptate que aut faceaque pa conem labo. Lorpos mint, illis que pos sanctum entoreped quia.



Scrivania ampia, ma compatta. Lo spazio di lavoro non ha limiti di progettazione, grazie agli allunghi complanari dall'elevato rigore funzionale.

Is eumqui ilitiam, qui ulpa quo voluptate que aut faceaque pa conem labo. Lorpos mint, illis que pos sinctum entoreped quia.

Is eumqui ilitiam, qui ulpa quo voluptate que aut faceaque pa conem labo. Lorpos mint, illis que pos sinctum entoreped quia.



Scrivania ampia, ma compatta. Lo spazio di lavoro non ha limiti di progettazione, grazie agli allunghi complanari dall'elevato rigore funzionale.

Is eumqui ilitiam, qui ulpa quo voluptate que aut faceaque pa conem labo. Lorpos mint, illis que pos sinctum entoreped quia.

Is eumqui ilitiam, qui ulpa quo voluptate que aut faceaque pa conem labo. Lorpos mint, illis que pos sinctum entoreped quia.





Massima efficienza tecnologica con il sistema di passaggio cavi, indispensabile per una postazione di lavoro pratica e confortevole.

Is eumqui ilitiam, qui ulpa quo voluptate que aut faceaque pa conem labo. Lorpos mint, illis que pos sinctum

Is eumqui ilitiam, qui ulpa quo voluptate que aut faceaque pa conem labo. Lorpos mint, illis que pos sinctum.



Mobili pensati per modellare l'ambiente lavorativo quotidiano e renderlo personalizzato, come il mobile contenitore con moduli a giorno e ad anta in melaminico.

Is eumqui ilitiam, qui ulpa quo voluptate que aut faceaque pa conem labo. Lorpos mint, illis que pos sinctum entoreped quia.

Is eumqui ilitiam, qui ulpa quo voluptate que aut faceaque pa conem labo. Lorpos mint, illis que pos sinctum entoreped quia.





Diverse tipologie di mobili a filo piano per comporre in infinite soluzioni d'arredo, volte alla produttività e al benessere nell'ambiente di lavoro.

Is eumqui ilitiam, qui ulpa quo voluptate que aut faceaque pa conem labo. Lorpos mint, illis que pos sinctum.

Is eumqui ilitiam, qui ulpa quo voluptate que aut faceaque pa conem labo. Lorpos mint, illis que pos sinctum.



Un gusto lievemente retrò, ma dal design originale e senza tempo. La curvatura del raccordo a 90° ha una sinuosità inconfondibile.

Is eumqui ilitiam, qui ulpa quo voluptate que aut faceaque pa conem labo. Lorpos mint, illis que pos sintum.

Is eumqui ilitiam, qui ulpa quo voluptate que aut faceaque pa conem labo. Lorpos mint, illis que pos sintum.



La classica finitura in noce rappresenta una scelta originale per conferire allo spazio operativo una forte caratterizzazione e un'aura di calore e luminosità.

Is eumqui ilitiam, qui ulpa quo voluptate que aut faceaque pa conem labo. Lorpos mint, illis que pos sanctum entoreped quia.

Is eumqui ilitiam, qui ulpa quo voluptate que aut faceaque pa conem labo. Lorpos mint, illis que pos sanctum entoreped quia.





La scrivania Fianco Legno dispone di due diverse dimensioni di fianco. La profondità di 57 cm dona una estetica più classica e tradizionale.

Is eumqui ilitiam, qui ulpa quo voluptate que aut faceaque pa conem labo. Lorpos mint, illis que pos sinctum .

Is eumqui ilitiam, qui ulpa quo voluptate que aut faceaque pa conem labo. Lorpos mint, illis que pos sinctum .



La profondità di 80 cm è caratterizzata da una linea unica e minimalista per un ambiente professionale e di alta classe.

Is eumqui ilitiam, qui ulpa quo voluptate que aut faceaque pa conem labo. Lorpos mint, illis que pos sinctum.

Is eumqui ilitiam, qui ulpa quo voluptate que aut faceaque pa conem labo. Lorpos mint, illis que pos sinctum.



Configurazioni originali, sia singole che aggregate, accostando le postazioni e mantenendo discrezione con l'inserimento di schermi fonoassorbenti, in melaminico o acrilici.

Is eumqui ilitiam, qui ulpa quo voluptate que aut faceaque pa conem labo. Lorpos mint, illis que pos sinctum entoreped quia.

Is eumqui ilitiam, qui ulpa quo voluptate que aut faceaque pa conem labo. Lorpos mint, illis que pos sinctum entoreped quia.







Melaminico | Melamine | Mélamine

<p>N3BD 25</p>	<p>Bianco Dance White Dance Blanc Dance</p>	<p>N2GN 25</p>	<p>Grigio Nuvola Cloud Grey Nuage Gris</p>	<p>N2AN 25</p>	<p>Acero Nordic Nordic Maple Érable Nordic</p>	<p>N3RT 25</p>	<p>Rovere Twist Durmast Twist Chêne Twist</p>	
<p>N2NO 25</p>	<p>Noce Walnut Noyer</p>	<p>N2GF 25</p>	<p>Grigio Fango Mud Grey Gris Boue</p>	<p>N3RV 25</p>	<p>Rovere Oak Chêne</p>	<p>N3NA 25</p>	<p>Noce Napoli Walnut Napoli Noyer Napoli</p>	
<p>N3NJ 25</p>	<p>Nero Jazz Black Jazz Noir Jazz</p>							

Grande gioco di abbinamenti cromatici e materici con l'ampia scelta di finiture in melaminico per le scrivanie da affiancare ai numerosi complementi della collezione.

Is eumqui ilitiam, qui ulpa quo voluptate que aut faceaque pa conem labo. Lorpos mint, illis que pos sinctum entoreped quia.

Is eumqui ilitiam, qui ulpa quo voluptate que aut faceaque pa conem labo. Lorpos mint, illis que pos sinctum entoreped quia.

Scrivanie

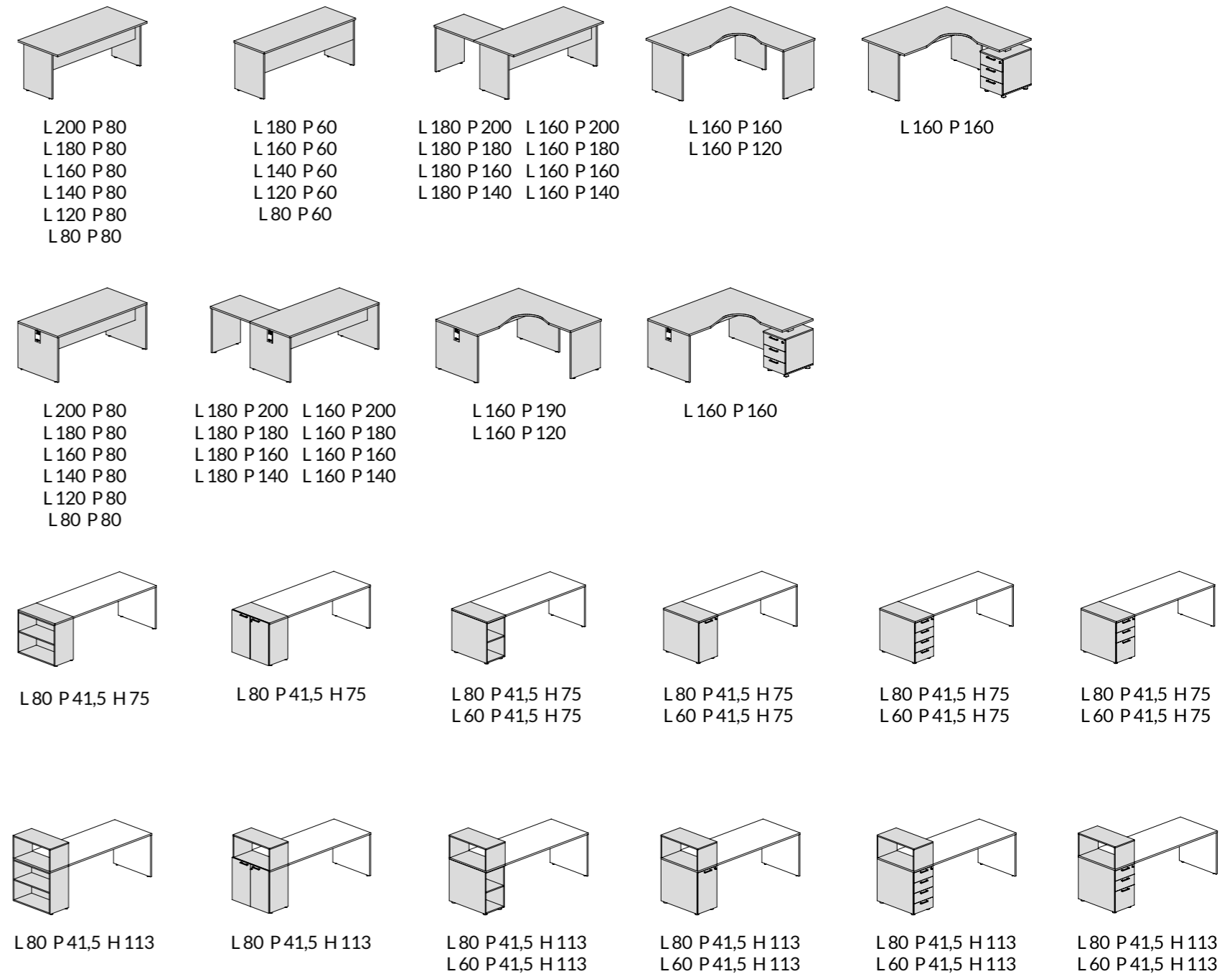

Tavoli Riunioni

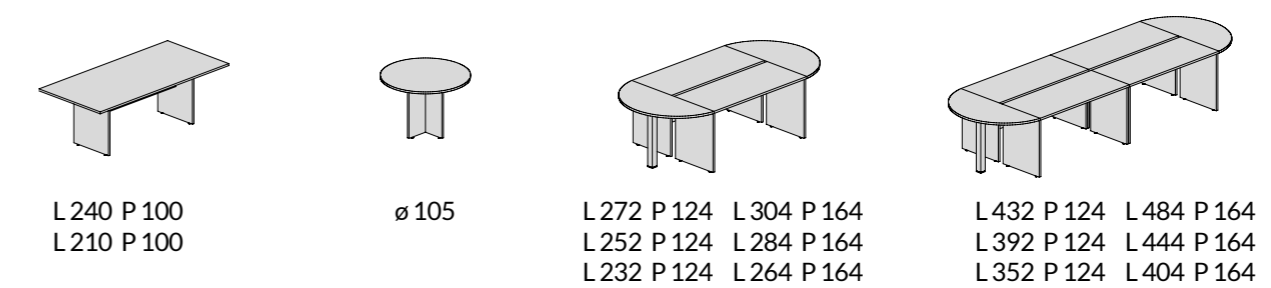

Gamba Csquare

Gamba Csquare

Gamba Csquare

L'innovazione si traduce in una struttura metallica originale e asimmetrica, disegnata rispettando la semplicità delle forme e la facilità di assemblaggio. Un design capace di dar vita a uno spazio professionale curandolo fino al minimo dettaglio grazie alle unioni armoniche tra i diversi materiali e colori.

Is eumqui ilitiam, qui ulpa quo voluptate que aut faceaque pa conem labo. Lorpos mint, illis que pos sinctum entoreped quia.

Is eumqui ilitiam, qui ulpa quo voluptate que aut faceaque pa conem labo. Lorpos mint, illis que pos sinctum entoreped quia.

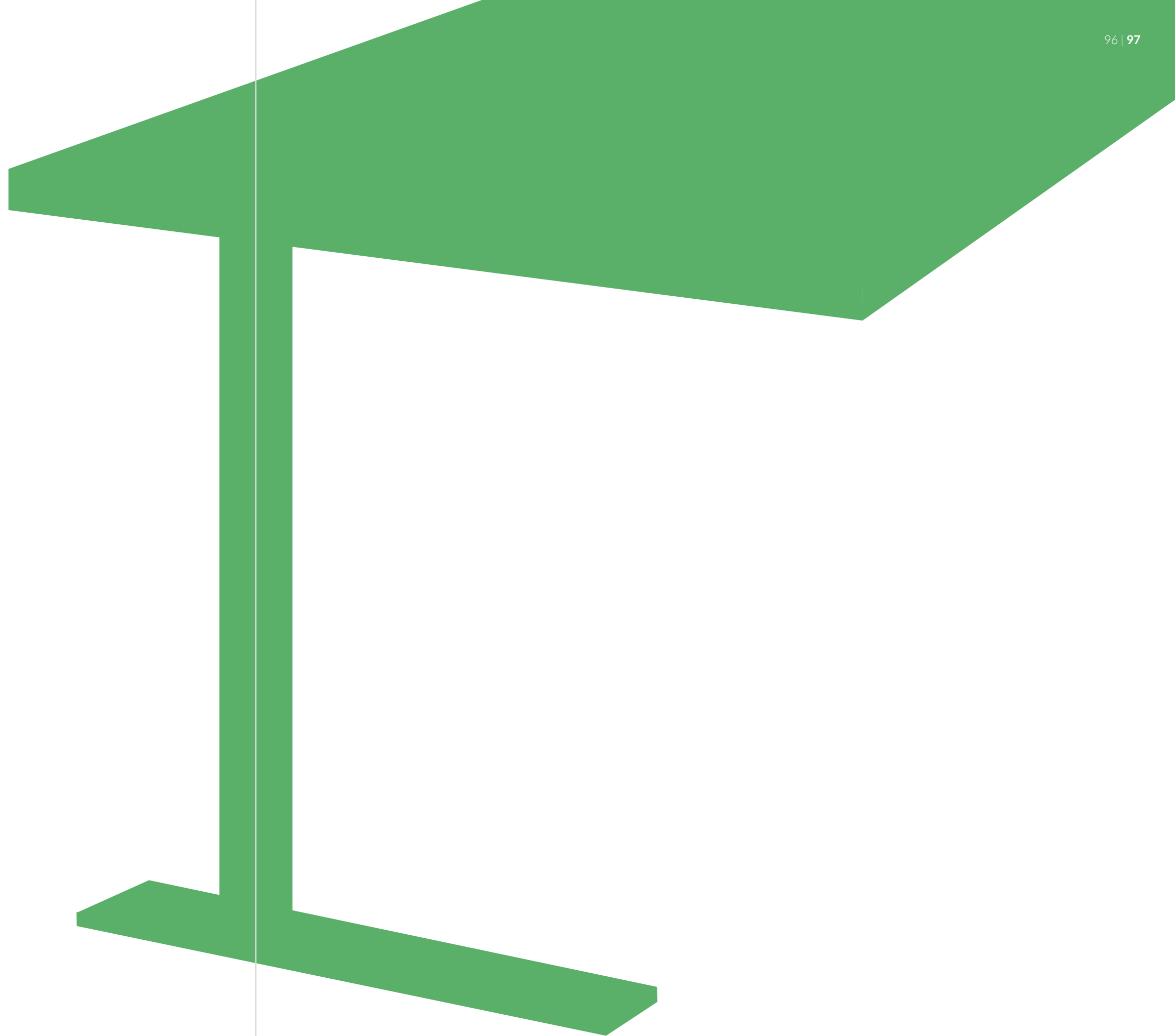



La postazione di lavoro con gamba Csquare sintetizza linearità e modernità per generare un ambiente attuale e dinamico.

Is eumqui ilitiam, qui ulpa quo voluptate que aut faceaque pa conem labo. Lorpos mint, illis que pos sinctum .

Is eumqui ilitiam, qui ulpa quo voluptate que aut faceaque pa conem labo. Lorpos mint, illis que pos sinctum entoreped.





Le combinazioni di bench e mobili di contenimento, filo-piano o di servizio, rendono le postazioni ampie e dotate di ogni comfort.

Is eumqui ilitiam, qui ulpa quo voluptate que aut faceaque pa conem labo. Lorpos mint, illis que pos sanctum entoreped quia.

Is eumqui ilitiam, qui ulpa quo voluptate que aut faceaque pa conem labo. Lorpos mint, illis que pos sanctum entoreped quia.







Allunghi e piani compatti sono la soluzione che permette di ampliare la superficie di lavoro in modo razionale e funzionale.

Is eumqui ilitiam, qui ulpa quo voluptate que aut faceaque pa conem labo. Lorpos mint, illis que pos sinctum entoreped quia.

Is eumqui ilitiam, qui ulpa quo voluptate que aut faceaque pa conem labo. Lorpos mint, illis que pos sinctum entoreped quia.





Postazioni ideali per spazi co-working: piena libertà di composizione e massima funzionalità.

The elegance of the meeting area is conveyed by the harmonious combination of open elements and closed modules, shaped and modular tables, bases and consoles.

L'élégance de l'espace de réunion est transmise par le mariage d'éléments ouverts et de modules fermés, de tables profilées et modulaires, d'éléments bas et de consoles.



I raccordi a 90° consentono di comporre tavoli riunione dalla superficie continua ed estremamente elegante.

Is eumqui ilitiam, qui ulpa quo voluptate que aut faceaque pa conem labo. Lorpos mint, illis que pos sinctum entoreped quia.

Is eumqui ilitiam, qui ulpa quo voluptate que aut faceaque pa conem labo. Lorpos mint, illis que pos sinctum entoreped quia.





Scrivanie | Desks | Bureaux

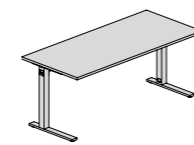

L 200 P 80
L 180 P 80
L 160 P 80
L 140 P 80
L 120 P 80
L 80 P 80

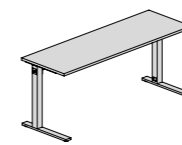

L 180 P 60
L 160 P 60
L 140 P 60
L 120 P 60
L 80 P 60

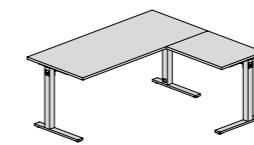

L 180 P 200 L 160 P 200
L 180 P 180 L 160 P 180
L 180 P 160 L 160 P 160
L 180 P 140 L 160 P 140

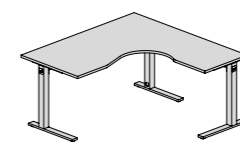

L 160 P 160
L 160 P 120

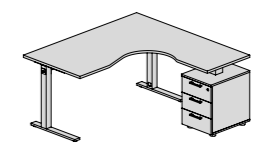

L 160 P 160

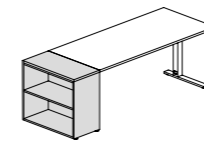

L 80 P 41,5 H 75

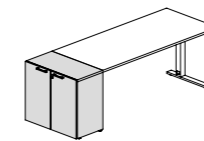

L 80 P 41,5 H 75

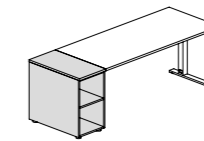

L 80 P 41,5 H 75
L 60 P 41,5 H 75

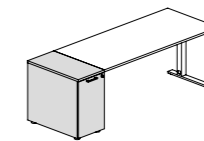

L 80 P 41,5 H 75
L 60 P 41,5 H 75

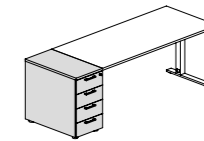

L 80 P 41,5 H 75
L 60 P 41,5 H 75

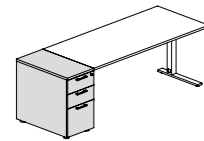

L 80 P 41,5 H 75
L 60 P 41,5 H 75

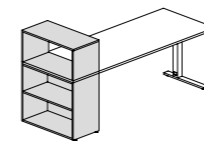

L 80 P 41,5 H 75

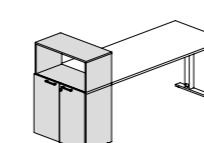

L 80 P 41,5 H 75

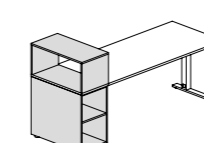

L 80 P 41,5 H 75
L 60 P 41,5 H 75

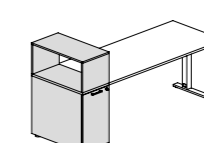

L 80 P 41,5 H 75
L 60 P 41,5 H 75

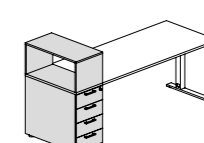

L 80 P 41,5 H 75
L 60 P 41,5 H 75

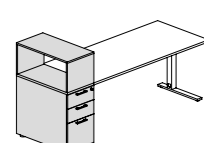

L 80 P 41,5 H 75
L 60 P 41,5 H 75

Melaminico | Melamine | Mèlamine

N3BD 25	Bianco Dance White Dance Blanc Dance	N2GN 25	Grigio Nuvola Cloud Grey Nuage Gris	N2AN 25	Acero Nordic Nordic Maple Érable Nordic	N3RT 25	Rovere Twist Durmast Twist Chêne Twist
N2NO 25	Noce Walnut Noyer	N2GF 25	Grigio Fango Mud Grey Gris Boue	N3RV 25	Rovere Oak Chêne	N3NA 25	Noce Napoli Walnut Napoli Noyer Napoli
N3NJ 25	Nero Jazz Black Jazz Noir Jazz						

Metallo | Metal | Métal

M2BD 25	Bianco Dance White Dance Blanc	M1NE 25	Nero Elegante Elegant Black Noir Éléphant	M2AG 25	Alluminio Goffrato Embossed Aluminum Aluminium Gaufré
------------	--------------------------------------	------------	---	------------	---

Tavoli Riunioni | Meeting Tables | Tables de Réunion

L 240 P 100 L 210 P 100	ø 105	L 272 P 124 L 304 P 164 L 252 P 124 L 284 P 164 L 232 P 124 L 264 P 164	L 432 P 124 L 484 P 164 L 392 P 124 L 444 P 164 L 352 P 124 L 404 P 164
----------------------------	-------	---	---

Lo stile unico della gamba Csquare è il risultato delle combinazioni tra i materiali e le finiture per il piano di lavoro e la struttura.

Is eumqui ilitiam, qui ulpa quo voluptate que aut faceaque pa conem labo. Lorpos mint, illis que pos sinctum entoreped quia.

Is eumqui ilitiam, qui ulpa quo voluptate que aut faceaque pa conem labo. Lorpos mint, illis que pos sinctum entoreped quia.

Gamba Tsquare

Gamba Tsquare

Gamba Tsquare

Composizioni leggere e facili da assemblare, dotate di una struttura metallica originale e di piani dalle proporzioni e i dettagli accurati. Possibilità aggiuntiva di alloggiare i cavi dell'elettificazione in maniera smart e versatile.

Is eumqui ilitiam, qui ulpa quo voluptate que aut faceaque pa conem labo. Lorpos mint, illis que pos sinctum entoreped quia.

Is eumqui ilitiam, qui ulpa quo voluptate que aut faceaque pa conem labo. Lorpos mint, illis que pos sinctum entoreped quia.

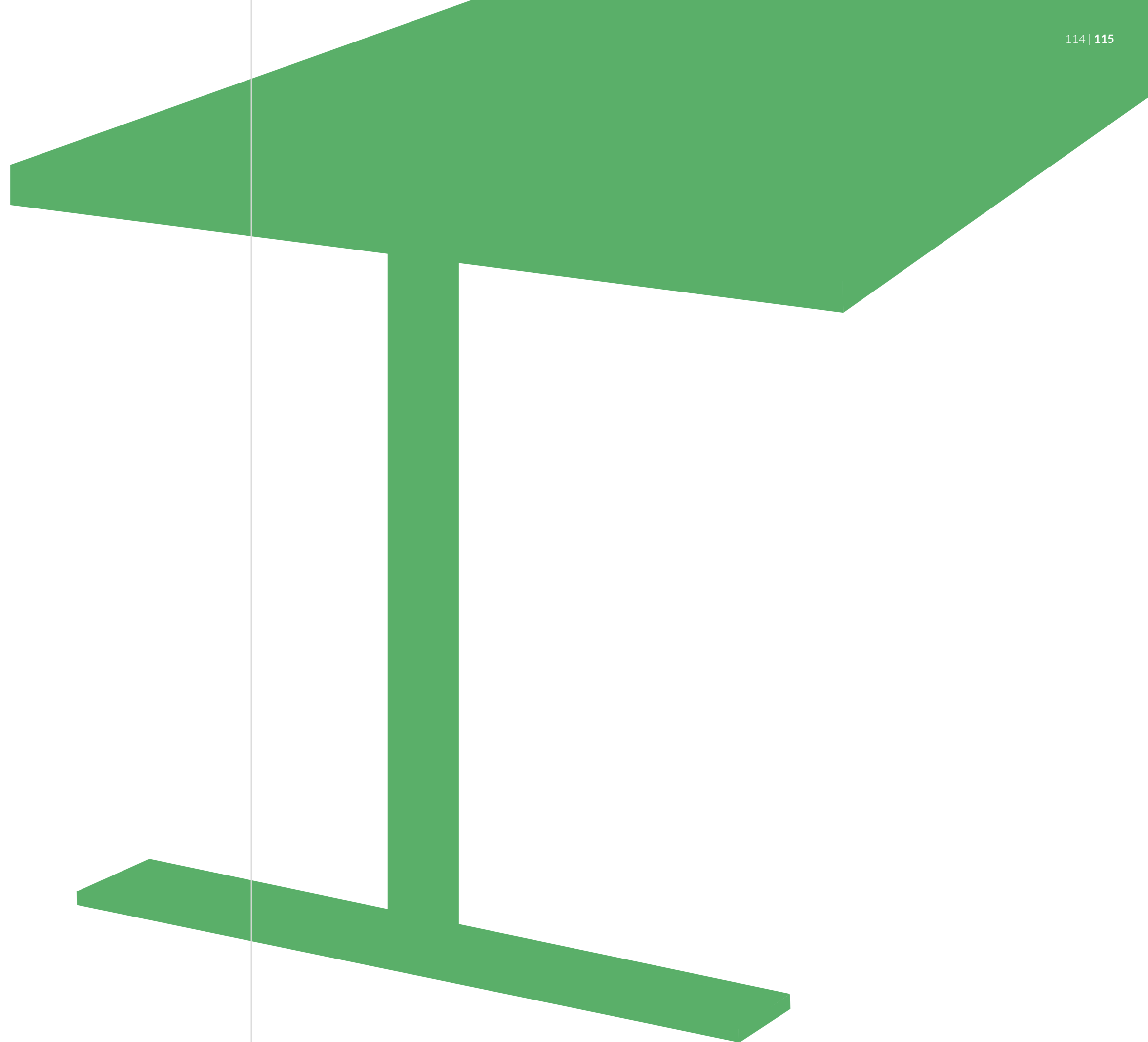



Una scrivania dalla struttura solida, seppur delicata e snella, e con piano di lavoro e gonna della medesima finitura per un'idea di continuità e classe.

Is eumqui ilitiam, qui ulpa quo voluptate que aut faceaque pa conem labo. Lorpos mint, illis que pos sanctum. Aliam dissert erteatrum tuusque prorte ium mentra.

Is eumqui ilitiam, qui ulpa quo voluptate que aut faceaque pa conem labo. Lorpos mint, illis que pos sanctum. Aliam dissert erteatrum tuusque prorte ium mentra.









Innovazione e design nel nuovo sistema di contenimento Lockers, con serratura standard o con combinazione, per il massimo della protezione e della privacy.

Is eumqui ilitiam, qui ulpa quo voluptate que aut faceaque pa conem labo. Lorpos mint, illis que pos sinctum entoreped quia. Eprati tem idem nom.

Is eumqui ilitiam, qui ulpa quo voluptate que aut faceaque pa conem labo. Lorpos mint, illis que pos sinctum entoreped quia. Eprati tem idem non eatiostrum qui.

Archiviazione alla portata di tutti con i mobili di servizio componibili e modulari, configurabili secondo le proprie esigenze.

Is eumqui ilitiam, qui ulpa quo voluptate que aut faceaque pa conem labo. Lorpos mint, illis que pos sinctum .

Is eumqui ilitiam, qui ulpa quo voluptate que aut faceaque pa conem labo. Lorpos mint, illis que pos sinctum .







Scrivanie | Desks | Bureaux

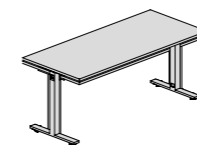

L 200 P 80
L 180 P 80
L 160 P 80
L 140 P 80
L 120 P 80
L 80 P 80

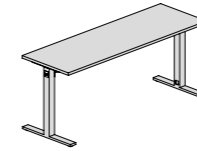

L 180 P 60
L 160 P 60
L 140 P 60
L 120 P 60
L 80 P 60

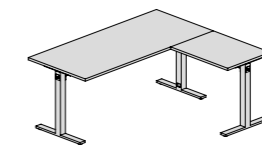

L 180 P 200 L 160 P 200
L 180 P 180 L 160 P 180
L 180 P 160 L 160 P 160
L 180 P 140 L 160 P 140

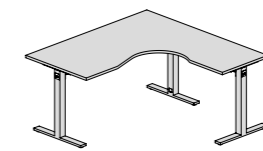

L 160 P 160
L 160 P 120

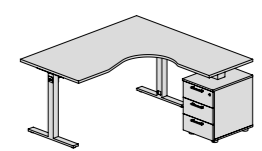

L 160 P 160

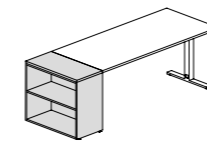

L 80 P 41,5 H 75

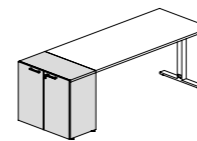

L 80 P 41,5 H 75

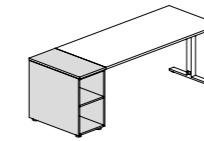

L 80 P 41,5 H 75
L 60 P 41,5 H 75

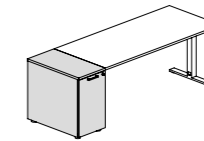

L 80 P 41,5 H 75
L 60 P 41,5 H 75

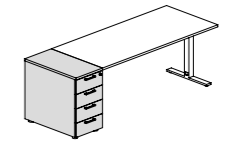

L 80 P 41,5 H 75
L 60 P 41,5 H 75

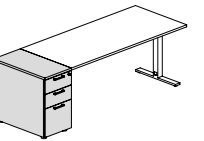

L 80 P 41,5 H 75
L 60 P 41,5 H 75

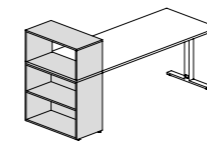

L 80 P 41,5 H 75

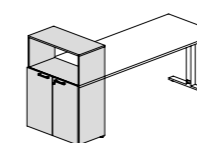

L 80 P 41,5 H 75

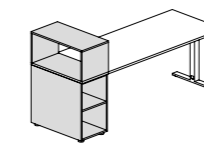

L 80 P 41,5 H 75
L 60 P 41,5 H 75

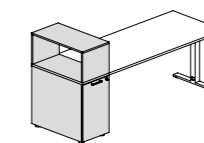

L 80 P 41,5 H 75
L 60 P 41,5 H 75

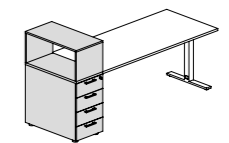

L 80 P 41,5 H 75
L 60 P 41,5 H 75

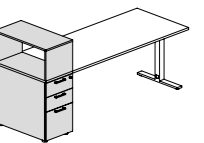

L 80 P 41,5 H 75
L 60 P 41,5 H 75

Melaminico | Melamine | Mélamine

N3BD 25	Bianco Dance White Dance Blanc Dance	N2GN 25	Grigio Nuvola Cloud Grey Nuage Gris	N2AN 25	Acero Nordic Nordic Maple Érable Nordic	N3RT 25	Rovere Twist Durmast Twist Chêne Twist
N2NO 25	Noce Walnut Noyer	N2GF 25	Grigio Fango Mud Grey Gris Boue	N3RV 25	Rovere Oak Chêne	N3NA 25	Noce Napoli Walnut Napoli Noyer Napoli
N3NJ 25	Nero Jazz Black Jazz Noir Jazz						

Metallo | Metal | Métal

M2BD 25	Bianco Dance White Dance Blanc	M1NE 25	Nero Elegante Elegant Black Noir Éléphant	M2AG 25	Alluminio Goffrato Embossed Aluminum Aluminium Gaufré
------------	--------------------------------------	------------	---	------------	---

Tavoli Riunioni | Meeting Tables | Tables de Réunion

L 240 P 100 L 210 P 100	ø 105	L 272 P 124 L 304 P 164 L 252 P 124 L 284 P 164 L 232 P 124 L 264 P 164	L 432 P 124 L 484 P 164 L 392 P 124 L 444 P 164 L 352 P 124 L 404 P 164
----------------------------	-------	---	---

Ampia scelta di finiture dei piani in melaminico, abbinabili a tutti gli accessori ed elementi di contenimento della famiglia Funny.

Is eumqui ilitiam, qui ulpa quo voluptate que aut faceaque pa conem labo. Lorpos mint, illis que pos sinctum entoreped quia.

Is eumqui ilitiam, qui ulpa quo voluptate que aut faceaque pa conem labo. Lorpos mint, illis que pos sinctum entoreped quia.

Gamba T

T Leg

Jambe T

La collezione ideale per ambienti operativi che necessitano di soluzioni immediate e versatili per il passaggio dell'elettificazione. Grande leggerezza compositiva e piena scelta degli abbinamenti tra le superfici in melaminico e la gamba T di sostegno.

Is eumqui ilitiam, qui ulpa quo voluptate que aut faceaque pa conem labo. Lorpos mint, illis que pos sinctum entoreped quia.

Is eumqui ilitiam, qui ulpa quo voluptate que aut faceaque pa conem labo. Lorpos mint, illis que pos sinctum entoreped quia.

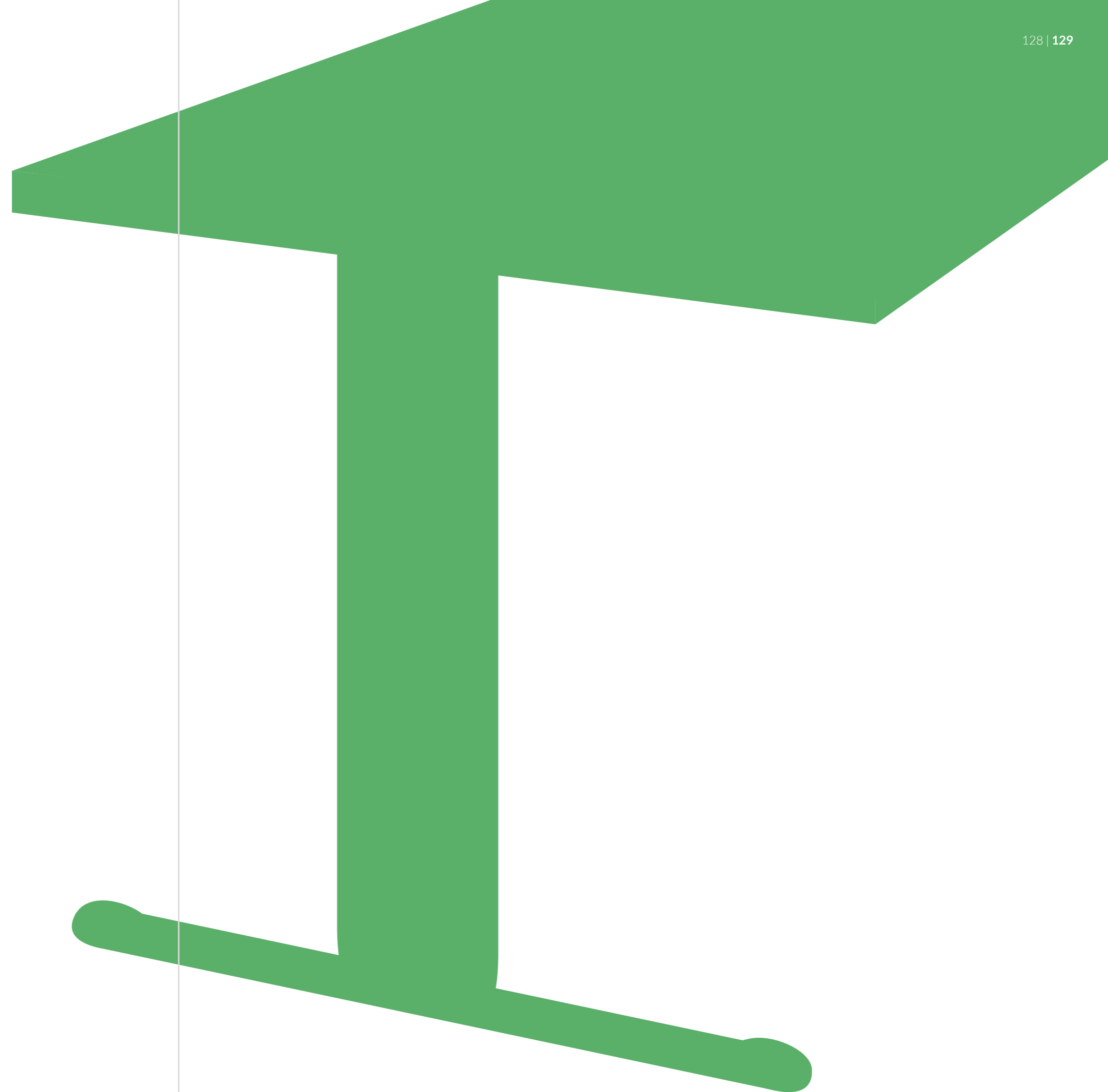



La scrivania con gamba T garantisce la massima funzionalità, ospitando il passaggio dei cavi elettrici all'interno della struttura metallica.

Is eumqui ilitiam, qui ulpa quo voluptate que aut faceaque pa conem labo. Lorpos mint, illis que pos sinctum entoreped quia.

Is eumqui ilitiam, qui ulpa quo voluptate que aut faceaque pa conem labo. Lorpos mint, illis que pos sinctum entoreped quia.







L'archiviazione raggiunge i massimi livelli accostando al tavolo o all'allungo mobili filo-piano, disponibili in tre varianti: a giorno, con ante, con cassetti.

Is eumqui ilitiam, qui ulpa quo voluptate que aut faceaque pa conem labo. Lorpos mint, illis que pos sinctum entoreped quia.

Is eumqui ilitiam, qui ulpa quo voluptate que aut faceaque pa conem labo. Lorpos mint, illis que pos sinctum entoreped quia.





Scrivanie | Desks | Bureaux

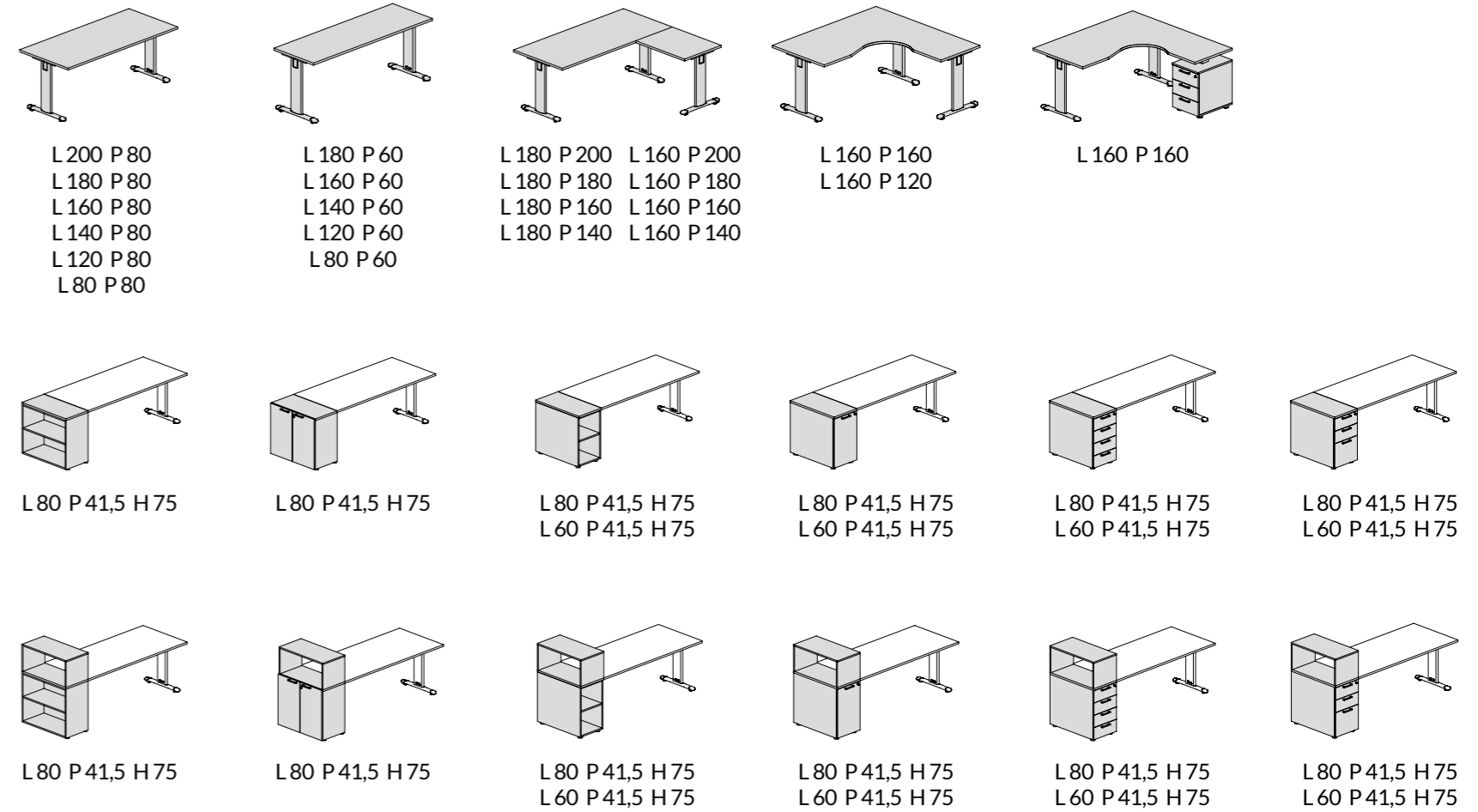

L 200 P 80
L 180 P 80
L 160 P 80
L 140 P 80
L 120 P 80
L 80 P 80

L 180 P 60
L 160 P 60
L 140 P 60
L 120 P 60
L 80 P 60

L 180 P 200 L 160 P 200
L 180 P 180 L 160 P 180
L 180 P 160 L 160 P 160
L 180 P 140 L 160 P 140

L 160 P 160
L 160 P 120

L 160 P 160

L 80 P 41,5 H 75

L 80 P 41,5 H 75

L 80 P 41,5 H 75
L 60 P 41,5 H 75

L 80 P 41,5 H 75
L 60 P 41,5 H 75

L 80 P 41,5 H 75
L 60 P 41,5 H 75

L 80 P 41,5 H 75
L 60 P 41,5 H 75

L 80 P 41,5 H 75

L 80 P 41,5 H 75

L 80 P 41,5 H 75
L 60 P 41,5 H 75

L 80 P 41,5 H 75
L 60 P 41,5 H 75

L 80 P 41,5 H 75
L 60 P 41,5 H 75

L 80 P 41,5 H 75
L 60 P 41,5 H 75

Melaminico | Melamine | Mèlamine

N3BD 25 Bianco Dance White Dance Blanc Dance	N2GN 25 Grigio Nuvola Cloud Grey Nuage Gris	N2AN 25 Acero Nordic Nordic Maple Érable Nordic	N3RT 25 Rovere Twist Durmast Twist Chêne Twist
N2NO 25 Noce Walnut Noyer	N2GF 25 Grigio Fango Mud Grey Gris Boue	N3RV Rovere Oak Chêne	N3NA Noce Napoli Walnut Napoli Noyer Napoli
N3NJ Nero Jazz Black Jazz Noir Jazz			

Metallo | Metal | Métal

M2BD Bianco Dance White Dance Blanc	M2AG Alluminio Goffrato Embossed Aluminum Aluminium Gouffré
--	--

Tavoli Riunioni | Meeting Tables | Tables de Réunion

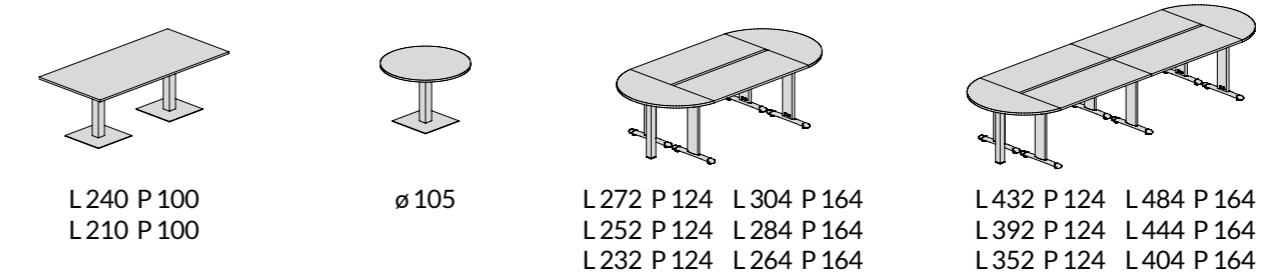

L 240 P 100
L 210 P 100

ø 105

L 272 P 124 L 304 P 164
L 252 P 124 L 284 P 164
L 232 P 124 L 264 P 164

L 432 P 124 L 484 P 164
L 392 P 124 L 444 P 164
L 352 P 124 L 404 P 164

Finiture in melaminico accuratamente studiate per esprimere appieno il gusto dell'azienda e rispettare l'eleganza complessiva dell'ufficio.

Is eumqui ilitiam, qui ulpa quo voluptate que aut faceaque pa conem labo. Lorpos mint, illis que pos sinctum entoreped quia.

Is eumqui ilitiam, qui ulpa quo voluptate que aut faceaque pa conem labo. Lorpos mint, illis que pos sinctum entoreped quia.

Smart Office

Smart Office

Smart Office

Oggi gli spazi di lavoro subiscono continui mutamenti e necessitano nuove soluzioni per restare al passo con la produttività. Per questo è stata elaborata la linea Smart Office. Una serie di progetti pensati per risolvere bisogni differenti rispettando il benessere e il comfort dell'ambiente lavorativo.

Is eumqui ilitiam, qui ulpa quo voluptate que aut faceaque pa conem labo. Lorpos mint, illis que pos sinctum entoreped quia.

Is eumqui ilitiam, qui ulpa quo voluptate que aut faceaque pa conem labo. Lorpos mint, illis que pos sinctum entoreped quia.





La postazione UP-GRADE permette di lavorare in maniera dinamica e di soddisfare le esigenze di flessibilità ed ergonomia. L'innovativo sistema sit or stand, dotato di regolazione elettrica dell'altezza del piano di lavoro, assicura massimo comfort sia da seduti, che in piedi.

Is eumqui ilitiam, qui ulpa quo voluptate que aut faceaque pa conem labo. Lorpos mint, illis que pos sinctum entoreped quia. Satiamqu emendam iamque convenatit consit. Are prat, nonostem, se pario habus consulto

Is eumqui ilitiam, qui ulpa quo voluptate que aut faceaque pa conem labo. Lorpos mint, illis que pos sinctum entoreped quia. Satiamqu emendam iamque convenatit consit. Are prat, nonostem, se pario habus consulto

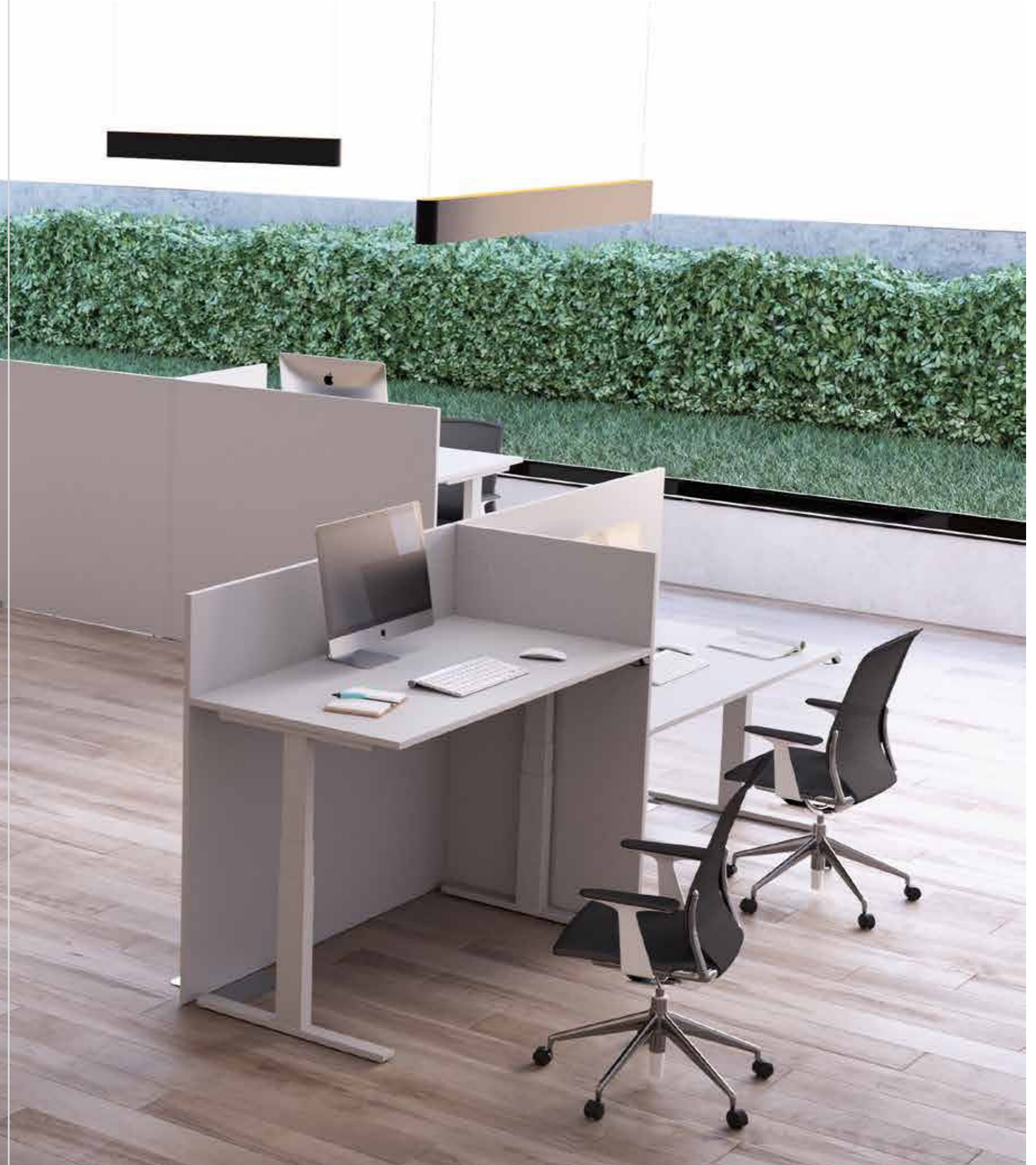
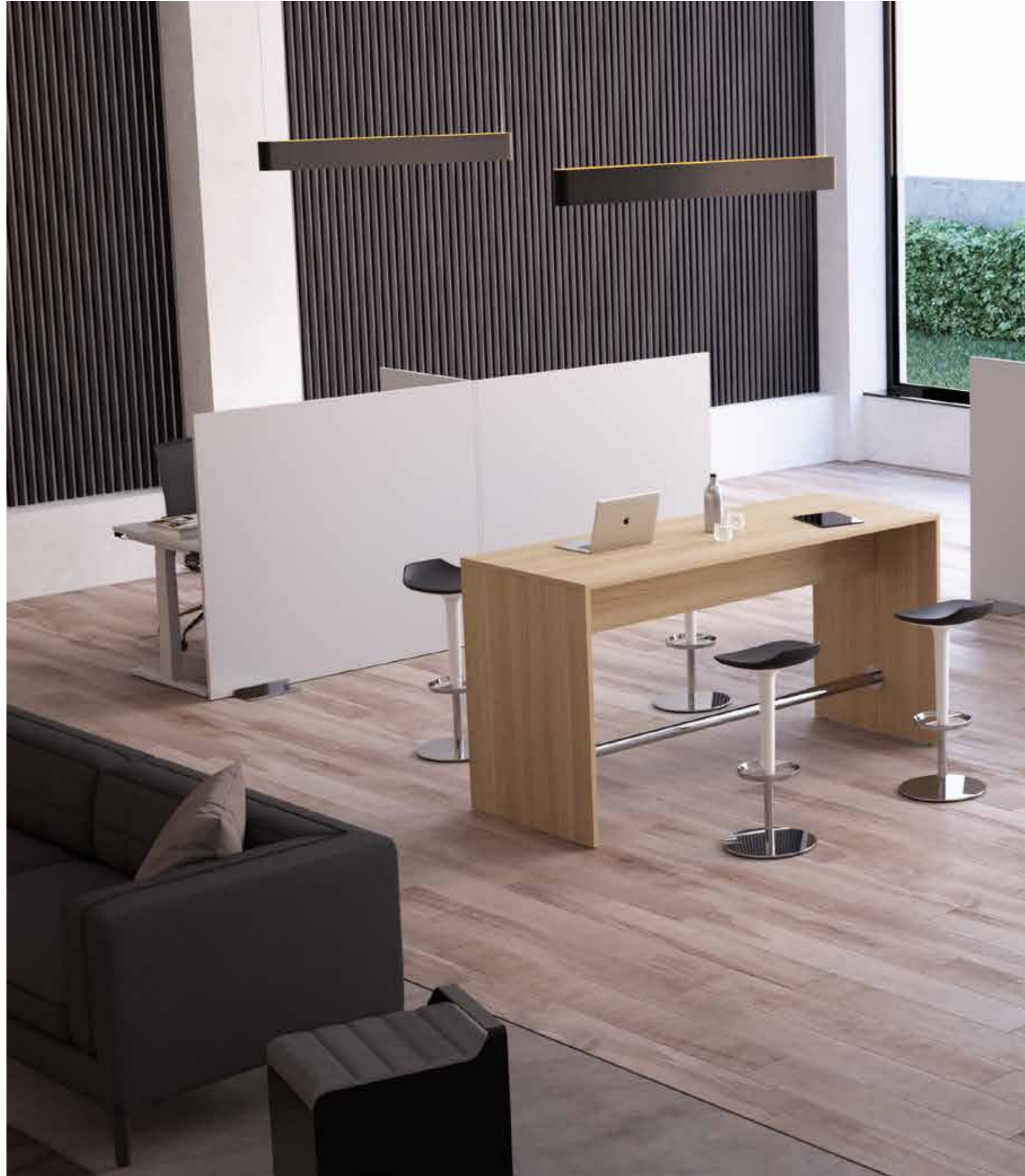



Piena libertà di movimento con la scrivania T-FLEX. La postazione su ruote con piano richiudibile è l'ideale per spazi ridotti e altamente dinamici.

Is eumqui ilitiam, qui ulpa quo voluptate que aut faceaque pa conem labo. Lorpos mint, illis que pos sinctum entoreped quia.

Is eumqui ilitiam, qui ulpa quo voluptate que aut faceaque pa conem labo. Lorpos mint, illis que pos sinctum entoreped quia.





Sistemazioni open space per call center in grado di facilitare la convivenza e rispettare la privacy individuale. Le postazioni modulari sono moltiplicabili all'infinito per un'organizzazione ottimale dello spazio.

Is eumqui ilitiam, qui ulpa quo voluptate que aut faceaque pa conem labo. Lorpos mint, illis que pos sanctum entoreped quia.

Is eumqui ilitiam, qui ulpa quo voluptate que aut faceaque pa conem labo. Lorpos mint, illis que pos sanctum entoreped quia.



Mobili di servizio e Cassettiere - Melaminico | Pedestals - MFC th. 18mm | Caissons - Mélamine ép.18

N3BD	Bianco Dance White Dance Blanc	N2GN	Grigio Nuvola Cloud Grey Nuage Gris	N2AN	Acero Nordic Nordic Maple Érable Nordic	N3RT	Rovere Twist Twist Durmast Twist Durmast	N2NO	Noce Walnut Noyer
N3RV	Rovere Durmast Durmast	N3NA	Noce Napoli Walnut Napoli Noyer Napoli	N2GF	Grigio Fango Mud Grey Gris Mud	N3NJ	Nero Jazz Jazz Black Noir Jazz		

Mobili di servizio - Metallo | Service units - Metal | Meubles de service - Métal

M2BD	Bianco Dance White Dance Blanc	M2AG	Alluminio Goffrato Embossed Aluminum Aluminium Gaufré	M3CF	Solo per TEAM TABLES Only for TEAM TABLES Uniquement pour TEAM TABLES
------	--------------------------------------	------	---	------	---

Mobili di servizio e Cassettiere - Melaminico | Pedestals - MFC th. 18mm | Caissons - Mélamine ép.18

N3BD	Bianco Dance White Dance Blanc	N2GN	Grigio Nuvola Cloud Grey Nuage Gris	N2AN	Acero Nordic Nordic Maple Érable Nordic	N3RT	Rovere Twist Twist Durmast Twist Durmast	N2NO	Noce Walnut Noyer
N3RV	Rovere Durmast Durmast	N3NA	Noce Napoli Walnut Napoli Noyer Napoli	N2GF	Grigio Fango Mud Grey Gris Mud	N3NJ	Nero Jazz Jazz Black Noir Jazz	M2AG	Struttura paretine Divisorie Only for TEAM TABLES Uniquement pour TEAM TABLES

Mobili di servizio e Cassettiere - Melaminico | Pedestals - MFC th. 18mm | Caissons - Mélamine ép.18

N3BD	Bianco Dance White Dance Blanc	N2GN	Grigio Nuvola Cloud Grey Nuage Gris	N2AN	Acero Nordic Nordic Maple Érable Nordic	N3RT	Rovere Twist Twist Durmast Twist Durmast	N2NO	Noce Walnut Noyer
N3RV	Rovere Durmast Durmast	N3NA	Noce Napoli Walnut Napoli Noyer Napoli	N2GF	Grigio Fango Mud Grey Gris Mud	N3NJ	Nero Jazz Jazz Black Noir Jazz	N2GN	Struttura Call Center - Melaminico Only for TEAM TABLES Uniquement pour TEAM TABLES

Mobili di servizio e Cassettiere - Melaminico | Pedestals - MFC th. 18mm | Caissons - Mélamine ép.18

N3BD	Bianco Dance White Dance Blanc	N2GN	Grigio Nuvola Cloud Grey Nuage Gris	N2AN	Acero Nordic Nordic Maple Érable Nordic	N3RT	Rovere Twist Twist Durmast Twist Durmast	N2NO	Noce Walnut Noyer	N3RV	Rovere Durmast Durmast
N2GF	Grigio Fango Mud Grey Gris Mud	N3NA	Noce Napoli Walnut Napoli Noyer Napoli	N3NJ	Nero Jazz Jazz Black Noir Jazz	N2AA	Azzurro Artico Jazz Black Noir Jazz	N2VP	Verde Pistacchio Twist Durmast Twist Durmast		

Strutture Lockers - Melaminico

N3BD	Bianco Dance White Dance Blanc	N2GN	Grigio Nuvola Cloud Grey Nuage Gris	N3NJ	Nero Jazz Jazz Black Noir Jazz
------	--------------------------------------	------	---	------	--------------------------------------

Upgrade

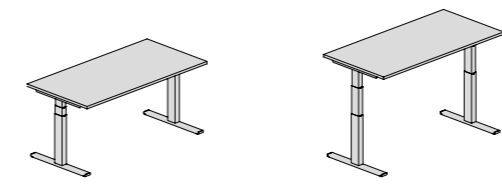

L 180 P 80 H 61/126 L 140 P 80 H 61/126
L 160 P 80 H 61/126 L 120 P 80 H 61/126

T-flex

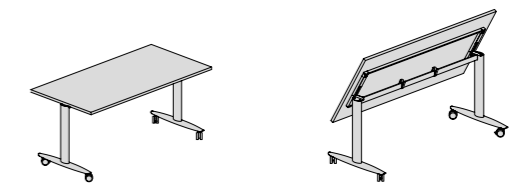

L 180 P 80 H 74 L 140 P 80 H 74
L 160 P 80 H 74 L 120 P 80 H 74

Team Tables

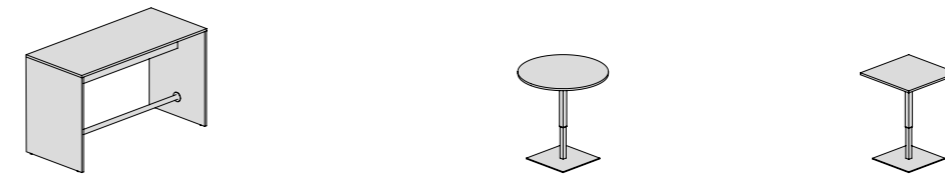

L 200 P 80 H 108 L 200 P 80 H 108
L 180 P 80 H 108 L 180 P 80 H 108
Ø 105 H 68/108 L 80 P 80 H 68/108

Paretine divisorie - Partition screens - Cloisons

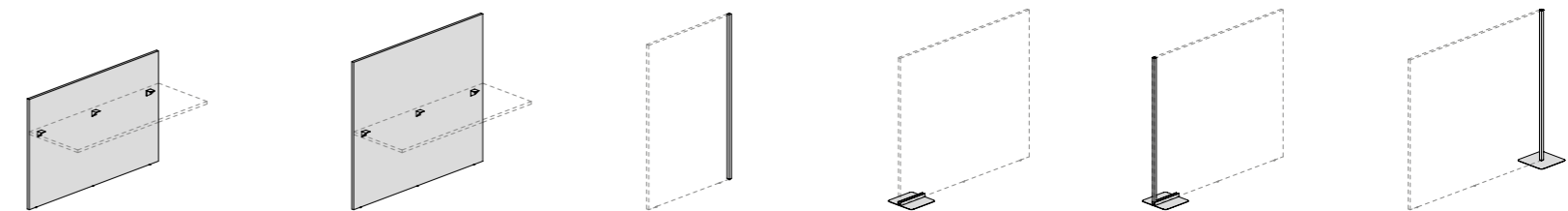

L 180 H 105 L 120 H 105 L 2,5 P 2,5 H 140 L 80 P 80 H 68/108 L 30 P 30
L 160 H 105 L 80 H 105 L 2,5 P 2,5 H 105 L 30 P 30 H 140 L 30 P 30 H 105
L 140 H 105 L 60 H 105 L 30 P 30 H 140 L 30 P 30 H 105

Call Center

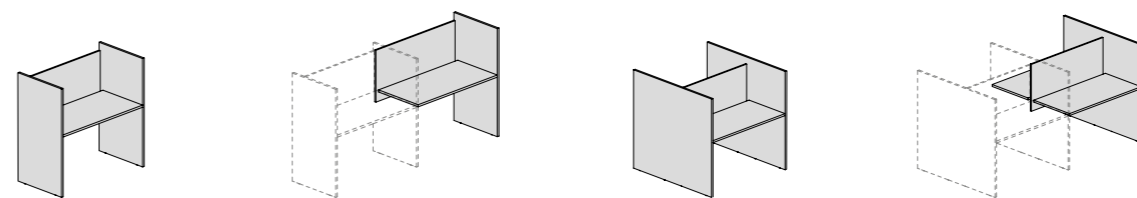

L 125 P 66 H 126 L 122,5 P 66 H 126 L 125 P 130 H 126 L 122,5 P 130 H 126
L 105 P 66 H 126 L 102,5 P 66 H 126 L 105 P 130 H 126 L 102,5 P 130 H 126

Lockers

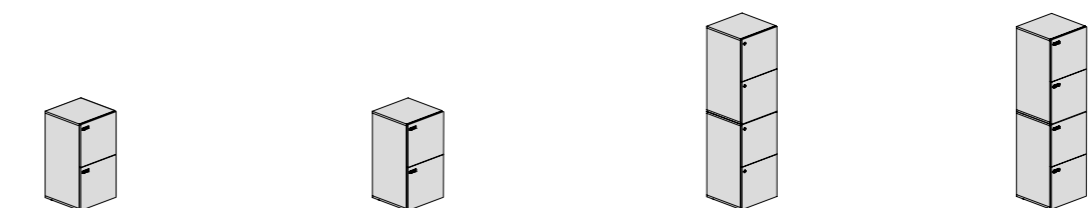

L 125 P 66 H 126 L 122,5 P 66 H 126 L 125 P 130 H 126 L 122,5 P 130 H 126

Le numerose colorazioni delle ricercate finiture in melaminico e dei diversi materiali mantengono la continuità tra spazi lavorativi diversi.

Is eumqui ilitiam, qui ulpa quo voluptate que aut faceaque pa conem labo. Lorpos mint, illis que pos sinctum

Is eumqui ilitiam, qui ulpa quo voluptate que aut faceaque pa conem labo. Lorpos mint, illis que pos sinctum

Reception

Reception

Reception

La reception è il luogo che rivela il carattere e l'immagine di un'azienda. Le linee pulite, le ampie superfici, i volumi, accolgono e soddisfano le necessità operative di chi lavora.

The reception environment sets the tone and reflects the image of a company. The clean lines, broad surfaces and shapes are welcoming and meet the functional needs of the people who work there.

La réception révèle le caractère et l'image d'une entreprise. Les lignes sobres, les volumes et les vastes surfaces accueillent et répondent aux besoins des réceptionnistes.

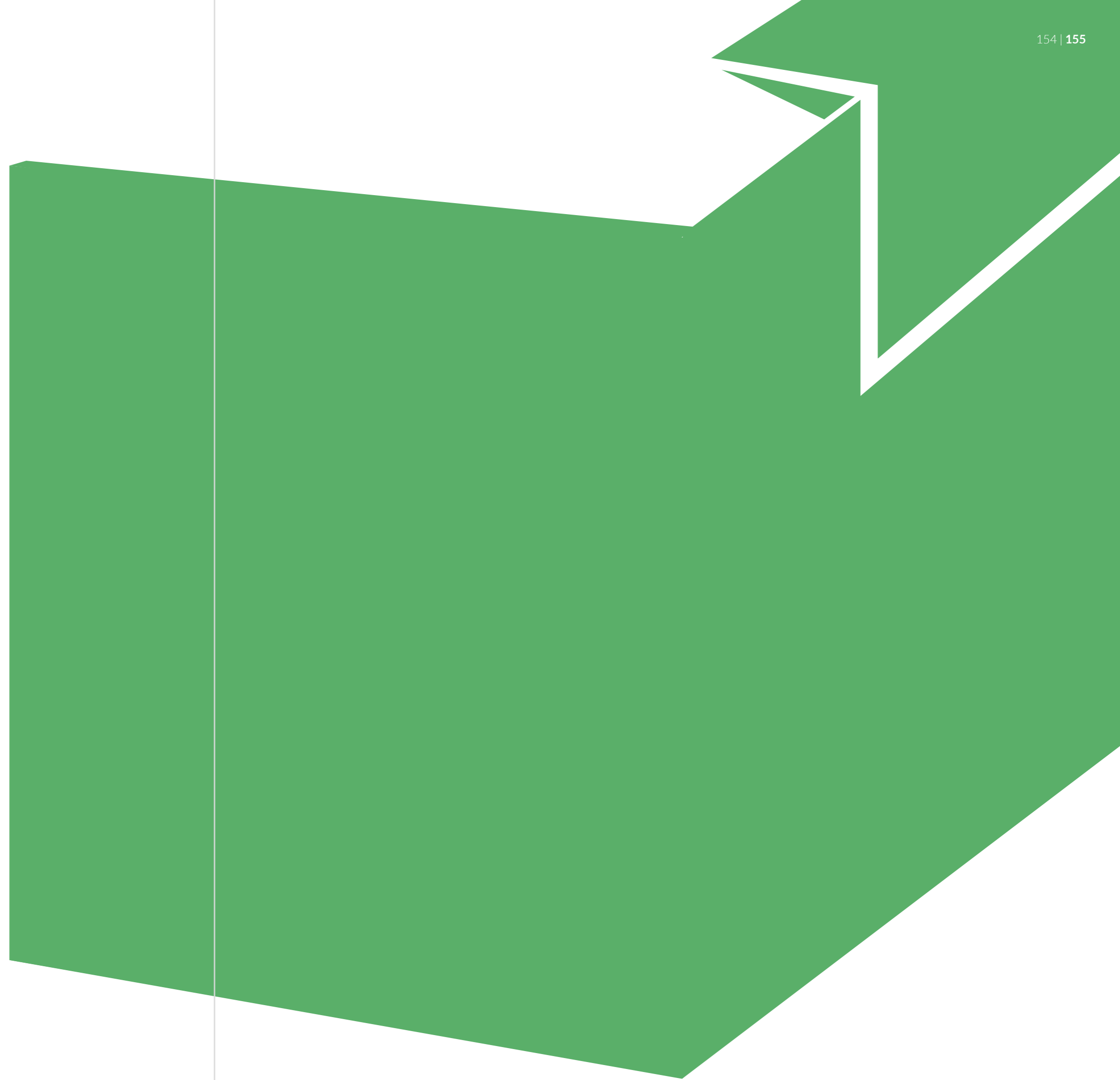

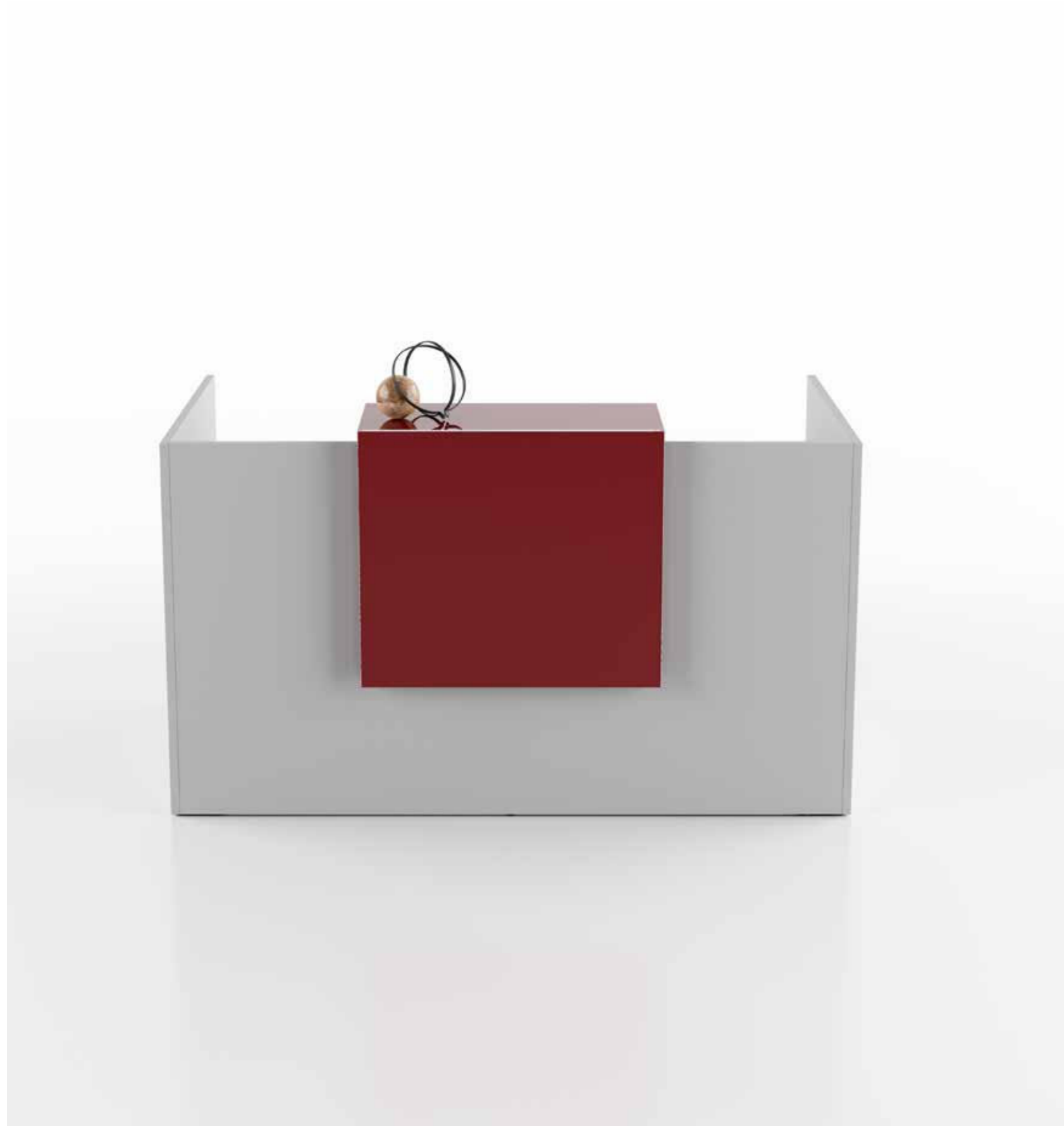

I diversi componenti e la varietà di finiture permettono di realizzare soluzioni compositive che danno risposte immediate alle priorità funzionali.

The different components and variety of finishes allow the creation of compositions that give immediate answers to functional priorities.

Les différents composants et la variété de finitions permettent de réaliser compositions qui donnent réponses immédiates aux priorités fonctionnelles.

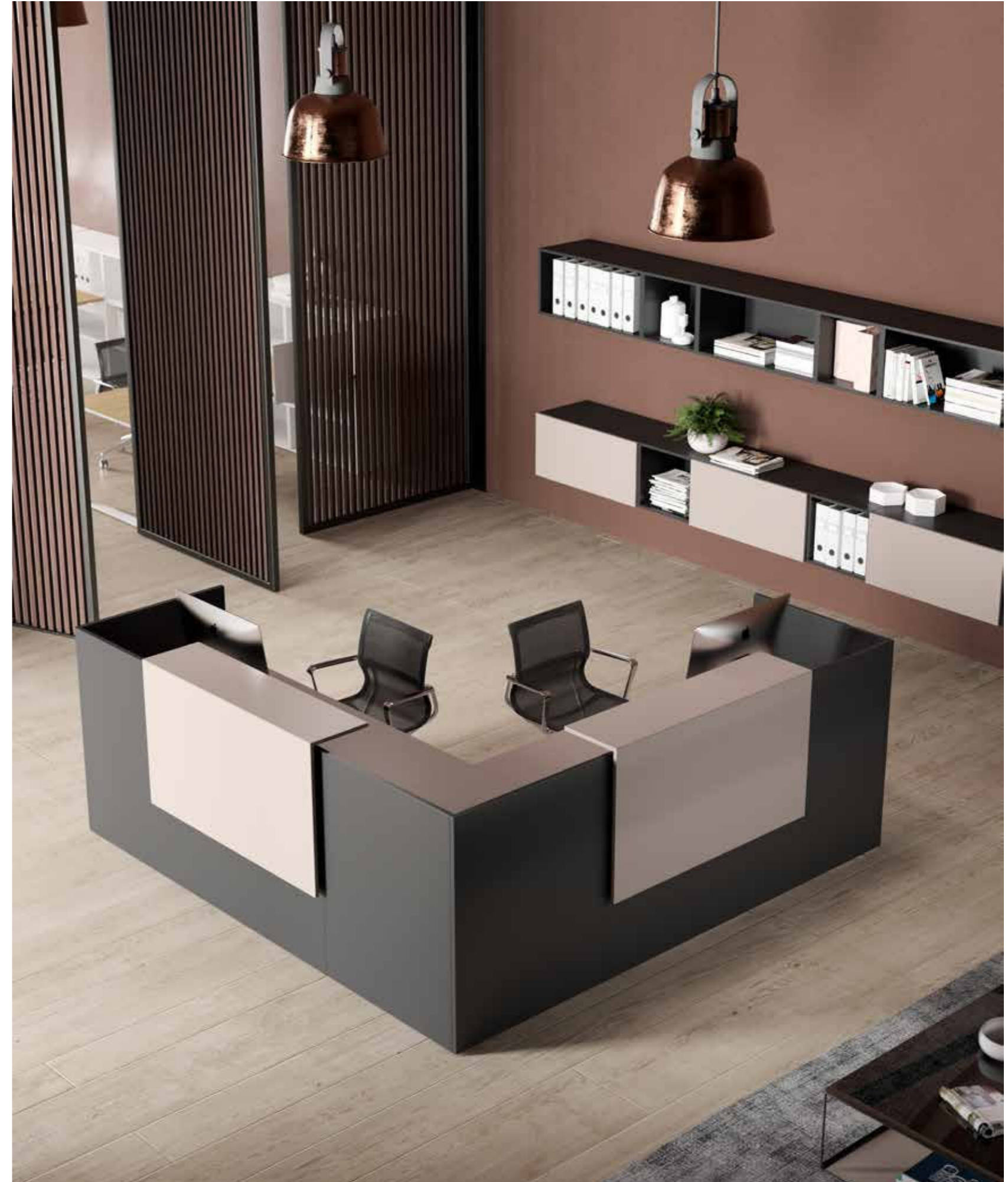



La semplicità compositiva del bancone e la mensola ad altezza totale rappresentano il perfetto biglietto da visita per una reception flessibile ed elegante.

The elegance of the meeting area is conveyed by the harmonious combination of open elements and closed modules, shaped and modular tables, bases and consoles.

L'élégance de l'espace de réunion est transmise par le mariage d'éléments ouverts et de modules fermés, de tables profilées et modulaires, d'éléments bas et de consoles.







Il piano di lavoro può essere attrezzato con funzionali box multiuso, da posizionare a piacere sotto la mensola top.

The work surface can be equipped with multipurpose functional boxes, arranged as desired below the top shelf.

Le plan de travail peut être équipé de caissons multifonctionnels, à positionner sous le plateau supérieur.

La luce led funge da cornice per i mobili e le pareti creando effetti scenografici d'impatto. L'arredo risulta valorizzato e intrigante.

Is eumqui ilitiam, qui ulpa quo voluptate que aut faceaque pa conem labo. Lorpos mint, illis que pos sanctum entoreped quia.

Is eumqui ilitiam, qui ulpa quo voluptate que aut faceaque pa conem labo. Lorpos mint, illis que pos sanctum entoreped quia.





Colori audaci, contrasto tra la finitura matt del melaminico e la riflessione del vetro creano ambienti attuali e dal carattere eccentrico.

Is eumqui ilitiam, qui ulpa quo voluptate que aut faceaque pa conem labo. Lorpos mint, illis que pos sanctum entoreped quia.

Is eumqui ilitiam, qui ulpa quo voluptate que aut faceaque pa conem labo. Lorpos mint, illis que pos sanctum entoreped quia.





Frontali sp.25 | Pedestals - MFC th. 18mm | Caissons - Mélamine ép.18

N3BD	Bianco Dance White Dance Blanc	N2GF	Grigio Fango Mud Grey Gris Mud	N2AN	Acero Nordic Nordic Maple Érable Nordic	N2GN	Grigio Nuvola Cloud Grey Nuage Gris
N3RV	Rovere Durmast Durmast	N3NA	Noce Napoli Walnut Napoli Noyer Napoli	N3RT	Rovere Twist Twist Durmast Twist Durmast	N2NO	Noce Walnut Noyer
N3NJ	Nero Jazz Jazz Black Noir Jazz						

Piani Melaminico sp.25 | Service units - MFC th. 18mm | Meubles de service - Mélamine ép.18

N3BD	Bianco Dance White Dance Blanc	N2GN	Grigio Nuvola Cloud Grey Nuage Gris	N2AN	Acero Nordic Nordic Maple Érable Nordic	N2GF	Grigio Fango Mud Grey Gris Mud
N3RV	Rovere Durmast Durmast	N3NA	Noce Napoli Walnut Napoli Noyer Napoli	N3RT	Rovere Twist Twist Durmast Twist Durmast	N2NO	Noce Walnut Noyer
N3NJ	Nero Jazz Jazz Black Noir Jazz						

Mensole Melaminico sp. 18 | Service units - Metal | Meubles de service - Métal

N3BD	Bianco Dance White Dance Blanc	N2GF	Grigio Fango Mud Grey Gris Mud	N2AN	Acero Nordic Nordic Maple Érable Nordic	N2GN	Grigio Nuvola Cloud Grey Nuage Gris
N3RV	Rovere Durmast Durmast	N3NA	Noce Napoli Walnut Napoli Noyer Napoli	N3RT	Rovere Twist Twist Durmast Twist Durmast	N2NO	Noce Walnut Noyer
N3NJ	Nero Jazz Jazz Black Noir Jazz	N2AA	Azzurro Artico Oak Chêne	N2VP	Verde Pistacchio Twist Durmast Twist Durmast		

Mensole Vetro | Service units - Metal | Meubles de service - Métal

E1BD	Bianco Dance White Dance Blanc Dance	E1GY	Grigio Yoga Yoga Grey Gris Yoga	V1NE	Nero Elegante Smart Black Noir Élégant	E1TT	Titanio Titanium Titane
E1GF	Grigio Fango Mud Grey Gris Boue	V1BV	Blu Vivo Sparkling Blue Blue Brillant	E1MS	Marsala Marsala Marsala	V1MK	Moka Moka Moka
E1DE	Denim Denim Denim	E1VF	Verde Foresta Forest Green Forêt Verte				

Frontali Laccati sp.25 | Service units - MFC th. 18mm | Meubles de service - Mélamine ép.18

L8BD	Bianco Dance White Dance Blanc	L8NY	Nero Yoga Yoga Black Gris Noire	L8GY	Grigio Yoga Yoga Grey Gris Yoga	L8TT	Titanio Titanium Titane
L8BV	Blu Vivo Sparkling Blue Blue Brillant	L8MS	Marsala Marsala Marsala	L8MK	Moka Moka Moka	L8TF	Tiffany Tiffany Tiffany
L8VM	Verde Muschio Walnut Noyer	L8VF	Verde Foresta Forest Green Forêt Verte	L8DE	Denim Denim Denim	L8GL	Glicine Oak Chêne
L8GZ	Giallo Zafferano Twist Durmast Twist Durmast	L8RM	Rosso Maranello Walnut Noyer				

Massima libertà di configurazione compositiva, materica e cromatica. I numerosi laccati si fondono ai melaminici e ai vetri offrendo molteplici abbinamenti.

Is eumqui ilitiam, qui ulpa quo voluptate que aut faceaque pa conem labo. Lorpos mint, illis que pos sinctum entoreped quia.

Is eumqui ilitiam, qui ulpa quo voluptate que aut faceaque pa conem labo. Lorpos mint, illis que pos sinctum entoreped quia.

Archiviazione

Storages

Rangement

**Is eumqui ilitiam, qui ulpa quo voluptate
que aut faceaque pa conem labo.
Lorpos mint, illis que pos sinctum
entoreped quia.**

Is eumqui ilitiam, qui ulpa quo voluptate
que aut faceaque pa conem labo.
Lorpos mint, illis que pos sinctum
entoreped quia.

Is eumqui ilitiam, qui ulpa quo voluptate
que aut faceaque pa conem labo. Lorpos
mint, illis que pos sinctum entoreped quia.

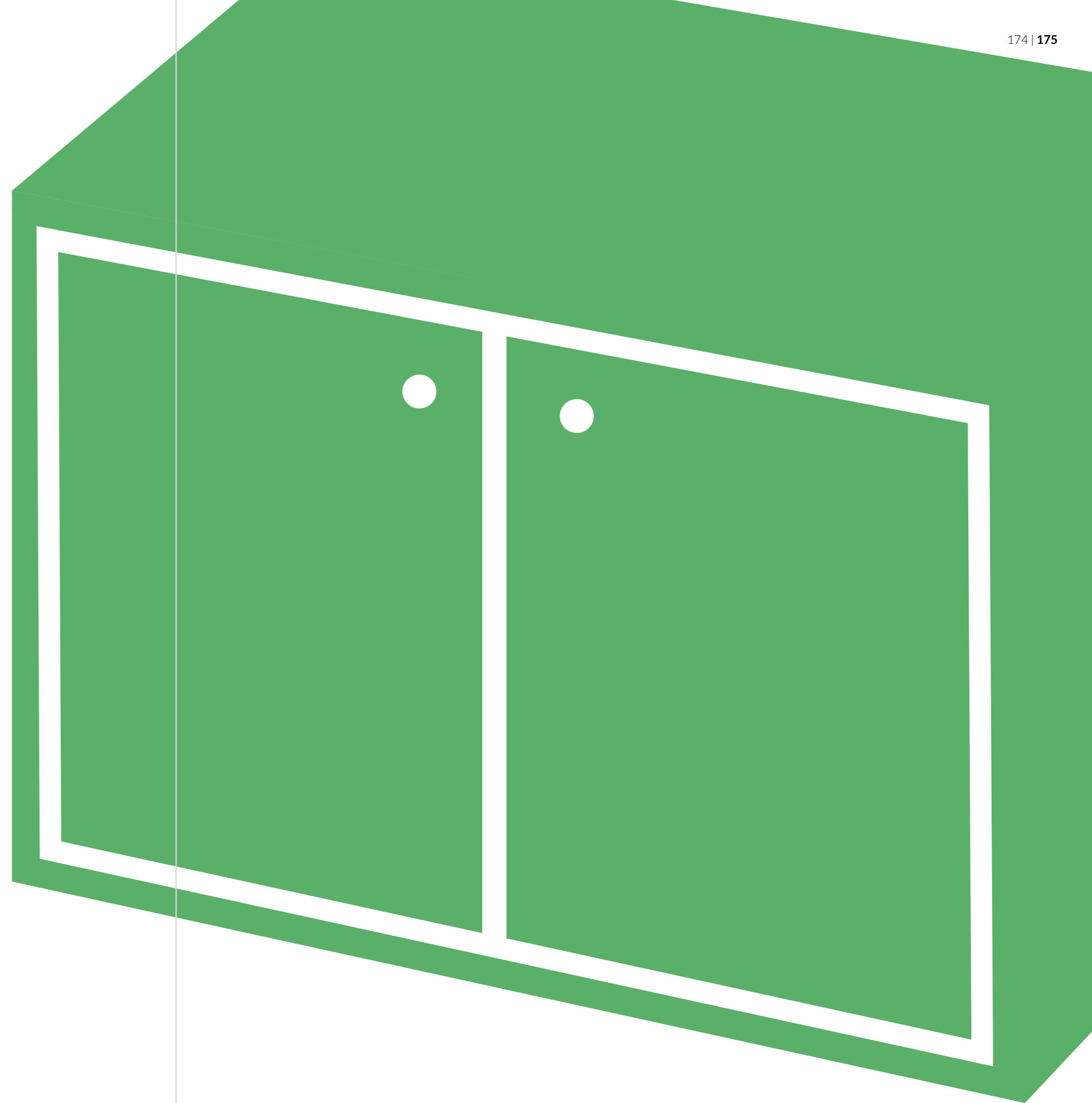

Is eumqui ilitiam, qui ulpa quo voluptate
que aut faceaque pa conem labo.
Lorpos mint, illis que pos sanctum
entoreped quia.

Is eumqui ilitiam, qui ulpa quo voluptate
que aut faceaque pa conem labo.
Lorpos mint, illis que pos sanctum
entoreped quia.

Is eumqui ilitiam, qui ulpa quo voluptate
que aut faceaque pa conem labo. Lorpos
mint, illis que pos sanctum entoreped quia.





Is eumqui ilitiam, qui ulpa quo voluptate que aut faceaque pa conem labo. Lorpos mint, illis que pos sintum entoreped quia.

Is eumqui ilitiam, qui ulpa quo voluptate que aut faceaque pa conem labo. Lorpos mint, illis que pos sintum entoreped quia.

Is eumqui ilitiam, qui ulpa quo voluptate que aut faceaque pa conem labo. Lorpos mint, illis que pos sintum entoreped quia.

Struttura Contenitori filo-piano - Melaminico | Service units - Metal | Meubles de service - Métal



Mobili di servizio e Cassettiere - Melaminico | Pedestals - MFC th. 18mm | Caissons - Mélamine ép.18



Sopralzo e schienale Contenitori filo-piano - Melaminico | Pedestals - MFC th. 18mm | Caissons - Mélamine ép.18

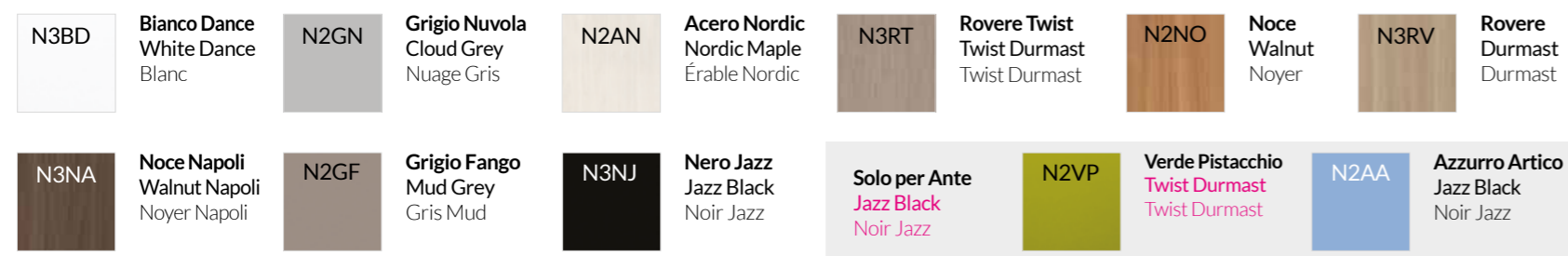

Sopralzo e schienale Contenitori filo-piano - Melaminico

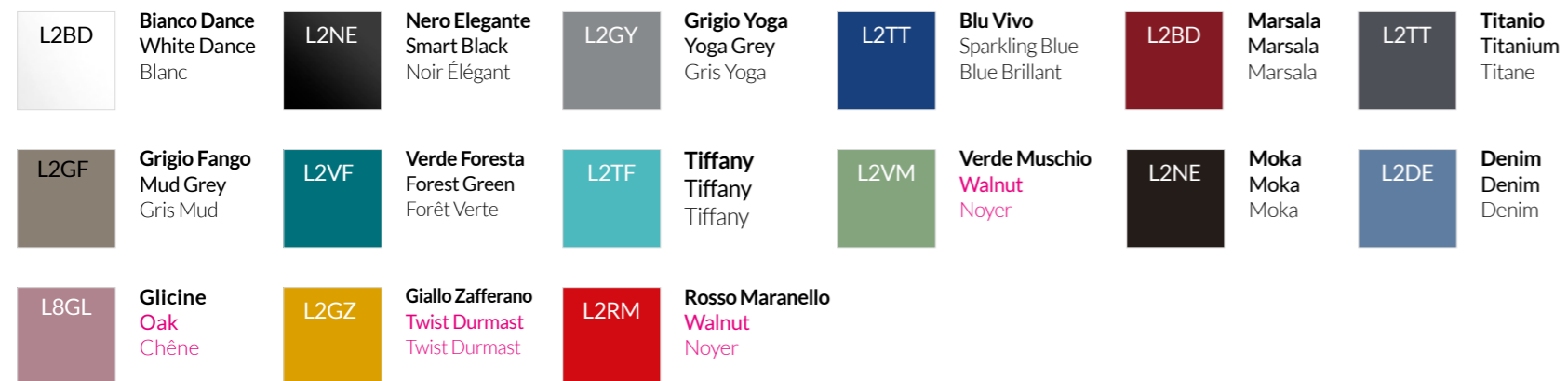

Mobili di servizio e Cassettiere - Melaminico | Pedestals - MFC th. 18mm | Caissons - Mélamine ép.18



Mobili di servizio - Metallo | Service units - Metal | Meubles de service - Métal

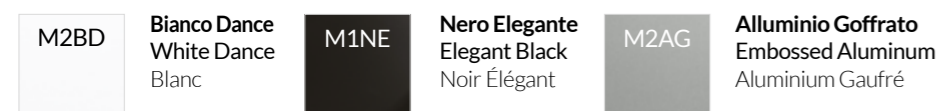

Contenitori filo-piano | Desks | Bureaux

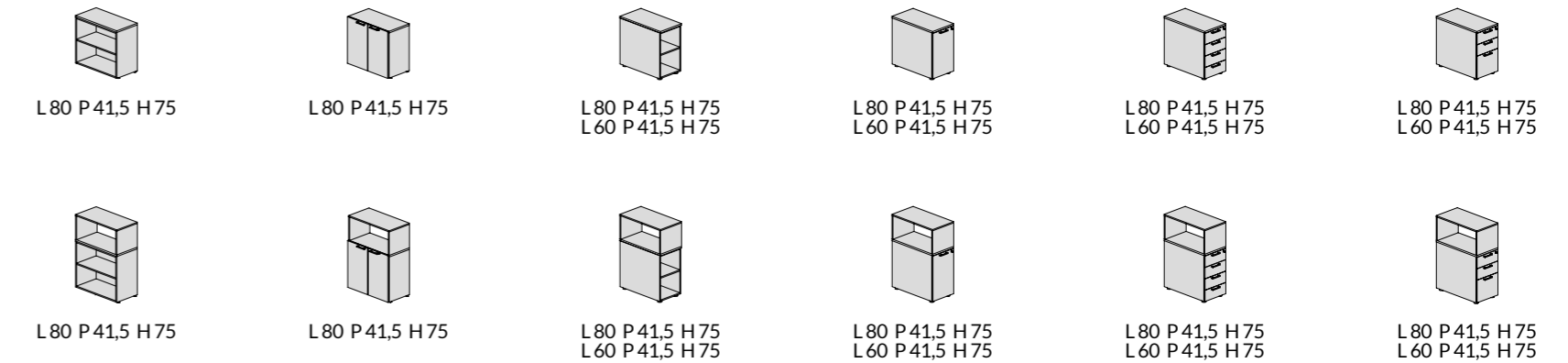

Mobili di servizio componibili | Desks | Bureaux

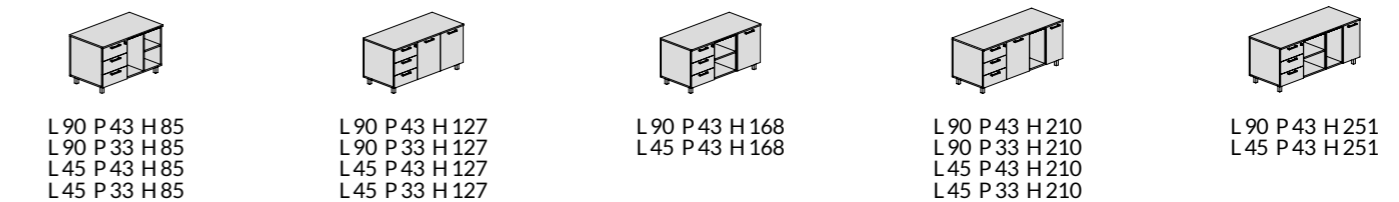

Cassettiere in melaminico | Desks | Bureaux

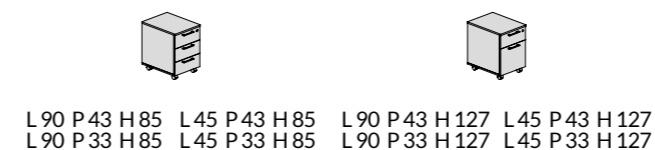

Cassettiere in metallo | Desks | Bureaux

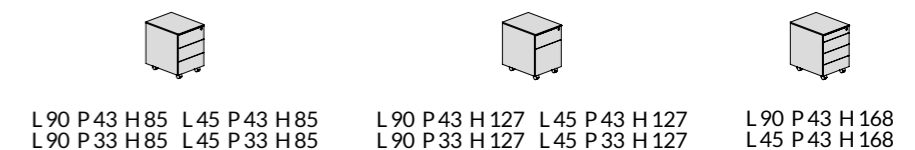

Armadi e contenitori - Struttura | Service units - Metal | Meubles de service - Métal

M2BD	Bianco Dance White Dance Blanc	N2GN	Grigio Nuvola Cloud Grey Nuage Gris	N3NJ	Nero Jazz Jazz Black Noir Jazz
------	---	------	--	------	---

Armadi e contenitori - Ante e frontali in Melaminico sp.18 | Service units - Metal | Meubles de service - Métal

N3BD	Bianco Dance White Dance Blanc	N2GN	Grigio Nuvola Cloud Grey Nuage Gris	N2AN	Acero Nordic Nordic Maple Érable Nordic	N3RT	Rovere Twist Twist Durmast Twist Durmast
N2NO	Noce Walnut Noyer	N2GF	Grigio Fango Mud Grey Gris Mud	N3RV	Rovere Durmast Durmast	N3NA	Noce Napoli Walnut Napoli Noyer Napoli
N3NJ	Nero Jazz Jazz Black Noir Jazz						







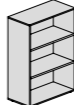
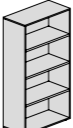
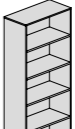
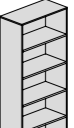



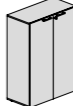
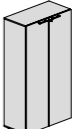
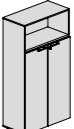

Armadi e contenitori - Vetro | Service units - Metal | Meubles de service - Métal

V2VS	Vetro Satinato Satinated Glass Verre Satiné	V1GE	Grigio Europeo European Grey Gris Européen
------	--	------	---



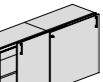
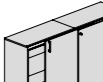
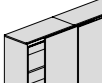

Mobili contenitore a giorno | Desks | Bureaux

				
L 90 P 43 H 85 L 90 P 33 H 85 L 45 P 43 H 85 L 45 P 33 H 85	L 90 P 43 H 127 L 90 P 33 H 127 L 45 P 43 H 127 L 45 P 33 H 127	L 90 P 43 H 168 L 45 P 43 H 168	L 90 P 43 H 210 L 90 P 33 H 210 L 45 P 43 H 210 L 45 P 33 H 210	L 90 P 43 H 251 L 45 P 43 H 251



Mobili contenitore con ante in melaminico | Desks | Bureaux

					
L 90 P 45 H 85 L 90 P 35 H 85 L 45 P 45 H 85 L 45 P 35 H 85	L 90 P 45 H 85 L 45 P 45 H 85	L 90 P 45 H 127 L 90 P 35 H 127 L 45 P 45 H 127 L 45 P 35 H 127	L 90 P 45 H 168 L 45 P 45 H 168	L 90 P 45 H 168 L 45 P 45 H 168	L 90 P 45 H 210 L 90 P 35 H 210 L 45 P 45 H 210 L 45 P 35 H 210
					
L 90 P 45 H 210 L 45 P 45 H 210	L 90 P 43 H 210 L 90 P 33 H 210 L 45 P 43 H 210 L 45 P 33 H 210	L 90 P 43 H 210 L 90 P 33 H 210 L 45 P 43 H 210 L 45 P 33 H 210	L 90 P 45 H 210 L 90 P 35 H 210 L 45 P 45 H 210 L 45 P 35 H 210	L 90 P 45 H 210	L 90 P 45 H 210
					
L 90 P 45 H 251 L 45 P 45 H 251	L 90 P 45 H 251 L 45 P 45 H 251		L 180 P 50,5 H 88	L 180 P 50,5 H 130	L 180 P 50,5 H 213

Mobili contenitore con ante in vetro e telaio alluminio | Desks | Bureaux

				
L 90 P 45 H 127 L 90 P 35 H 127 L 45 P 45 H 127 L 45 P 35 H 127	L 90 P 45 H 168 L 45 P 45 H 168	L 90 P 45 H 210 L 90 P 35 H 210 L 45 P 45 H 210 L 45 P 35 H 210	L 90 P 45 H 210 L 90 P 35 H 210 L 45 P 45 H 210 L 45 P 35 H 210	L 90 P 45 H 210

Mobili contenitore con ante in vetro fumè | Desks | Bureaux

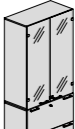
			
L 90 P 45 H 127 L 90 P 35 H 127 L 45 P 45 H 127 L 45 P 35 H 127	L 90 P 45 H 168 L 45 P 45 H 168	L 90 P 45 H 210 L 90 P 35 H 210 L 45 P 45 H 210 L 45 P 35 H 210	L 90 P 45 H 210 L 90 P 35 H 210 L 45 P 45 H 210 L 45 P 35 H 210

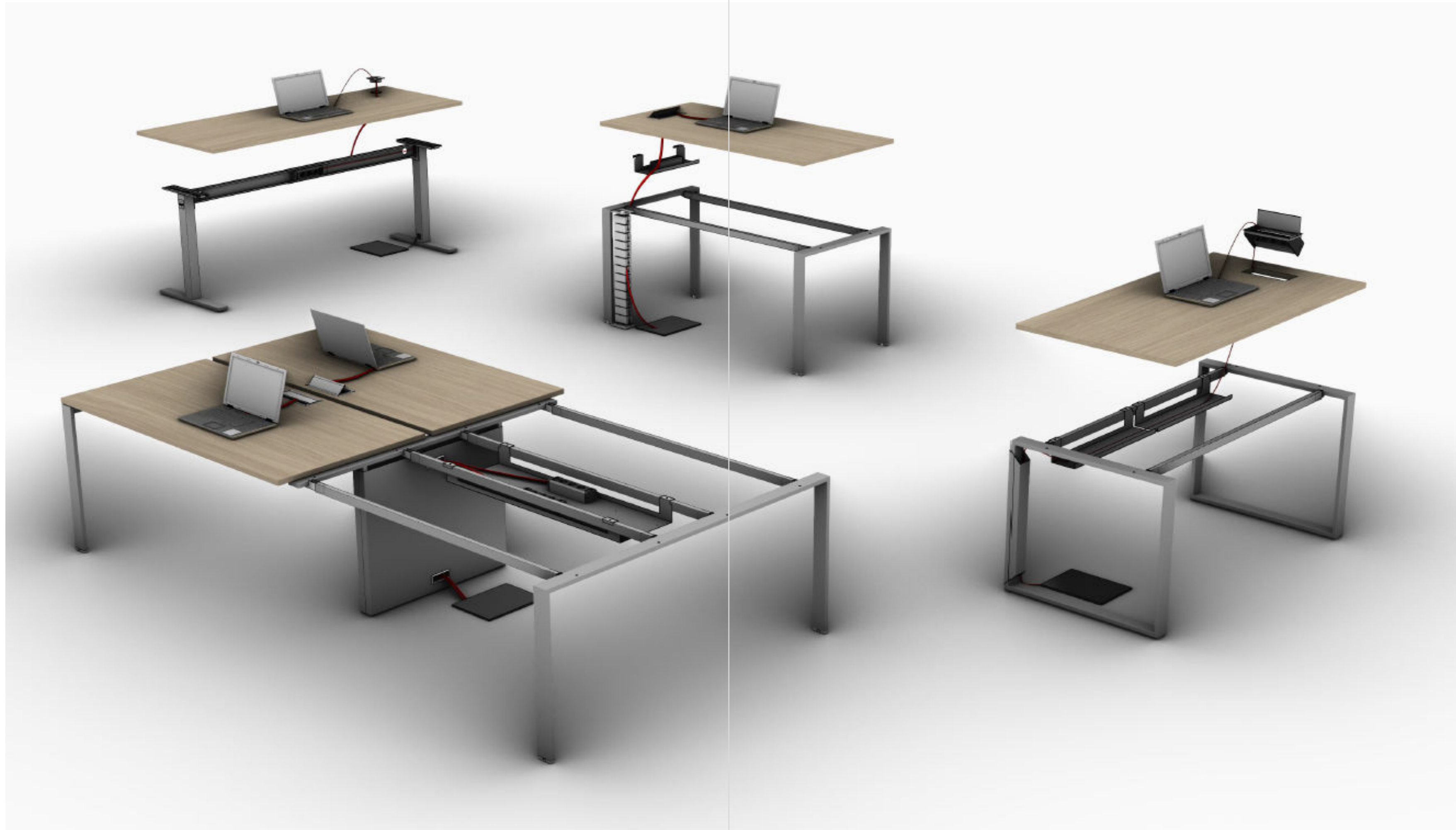

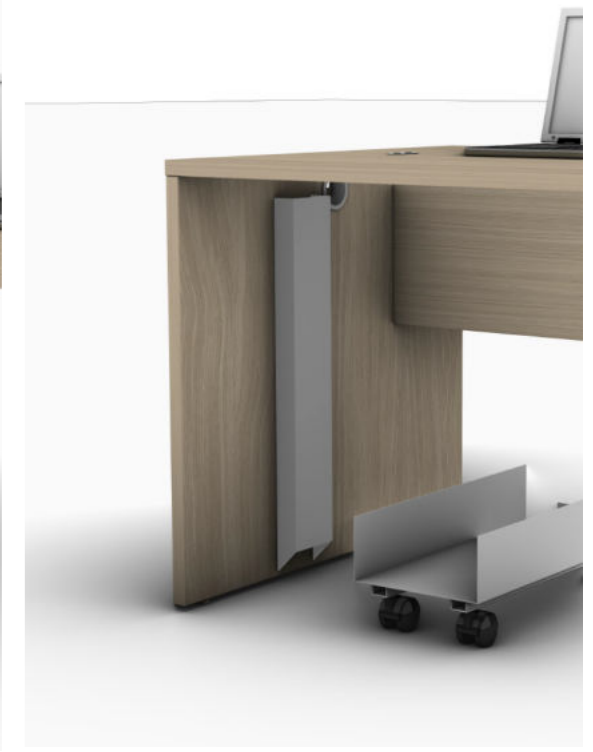

Mobilpref S.p.A. si riserva il diritto di apportare ai propri prodotti le modifiche ritenute utili o necessarie, senza pregiudicare le caratteristiche essenziali dei prodotti stessi. Foto e testi copyright Mobilpref S.p.A. Riproduzione senza autorizzazione non permessa.

Mobilpref S.p.A. reserves the right to apply changes to products deemed useful or necessary without compromising the essential product features. Photos and texts copyright Mobilpref S.p.A. Reproduction without authorization not allowed.

Mobilpref S.p.A. se réserve le droit d'apporter les modifications jugées utiles ou nécessaires à ses propres produits, sans compromettre les caractéristiques essentielles des produits eux-mêmes. Photos et textes Copyright Mobilpref S.p.A. La reproduction sans autorisation est interdite.

